

SERIES 20 CHAMBERS

A feature in common with all Series 20 chambers is the use of a glass coverslip for the floor of the chamber. In most cases, this same coverslip contains the imaging sample. When viewed with inverted microscopes, images are visualized through a single thickness of glass, usually 0.13-0.17 mm. (#1)

The design of the Series 20 chambers incorporates a diamond-shaped bath which has been shown to produce a laminar flow across the bath. Since bath volumes are generally small, exchange times are measured in seconds even when flow rates are less than 1 ml/min.



THE RC-20 AND RC-20H CHAMBER

The RC-20 and RC-20H chambers are small volume imaging chambers featuring rapid solution exchange, short working distances and a closed bath. The closed bath design of these chambers promotes an even and continuous solution exchange with no alteration in focus due to changes in bath height. In addition, studies using gassed solutions can be performed with no change in partial pressure at the chamber interface.

Two 15 mm diameter round coverslips enclose the bath with a distance of 1 mm between the top and bottom coverslip. The bath volumes for the RC-20 and RC-20H are 36 and 70 μ l, respectively. The chamber also features an injection port adjacent to the bath solution input port for direct introduction of substances or the removal of bubbles.

ASSEMBLY

A general procedure for the assembly of a Series 20 chamber is to first apply a coverslip to the chamber bottom and then place the assembly in the appropriate platform. The platform serves to (1) clamp the assembly together providing a tight seal between the chamber and coverslip and (2) provide a means to mount the chamber onto the microscope stage, usually via a microscope specific adapter plate.

The RC-20 and RC-20H chambers differ from this procedure in that the bottom coverslip is first mounted onto the *platform* and the chamber assembly is then completed on top of this coverslip (see directions below). The RC-20 and RC-20H chambers incorporate a coverslip mounted to the top of the chamber to provide an enclosed volume. The RC-20 is supplied with a small quantity (6) of 15 mm diameter #1 coverslips (0.13-0.17 mm thickness) and a tool (pry bar) for removing the coverslip retainer ring from the chamber top.

Application of vacuum grease

Vacuum grease can be applied to Warner chambers by use of a syringe or a small artist's dotting brush. Both approaches are described below.

NOTE: Prior to beginning assembly make sure all required components are available and thoroughly cleaned. Be sure to remove any old vacuum grease from the perfusion channels and input/output ports.

Brush technique

The brush technique is performed in a similar manner as described above except that the vacuum grease is applied using a #1 or #2 artist's dotting brush. Brushes can be found in your local art shop, university bookstore, or can be purchased from Warner.

NOTE: We suggest the brush technique since the resultant application of vacuum grease is more precise.

Syringe technique

Begin by loading a 1cc syringe with a small quantity of vacuum grease. The use of a needle is unnecessary and undesirable.

Using the syringe, apply a small bead of grease to the chamber as described below. Evenly distribute the grease by placing a spare coverslip into place and gently pressing it into position.

Remove and discard the spare coverslip and clean away any grease which may have entered the bath area. Pay particular attention to the perfusion input and outlet ports since the presence of grease in these areas will impede the flow of perfusate.

Assembling the Chamber

1. Begin by removing the coverslip retainer from the top of the chamber using the pry bar. Remove the installed coverslip. Place aside for later use.
2. Using the 1 cc syringe or brush, apply a small quantity of grease around the seat to which the top coverslip rests. Evenly distribute the grease around the seat by placing a spare coverslip into the chamber top and gently press it into position.
3. Remove and discard the coverslip. Clean away any grease which may have entered the bath area. Pay particular attention to the perfusion input and outlet ports since the presence of grease in these areas will impede the flow of perfusate.
4. Using the brush or a 1 cc syringe, apply a small quantity of grease to the coverslip groove on the *bottom of the chamber*. Evenly distribute the grease around the seat by placing a spare 15 mm

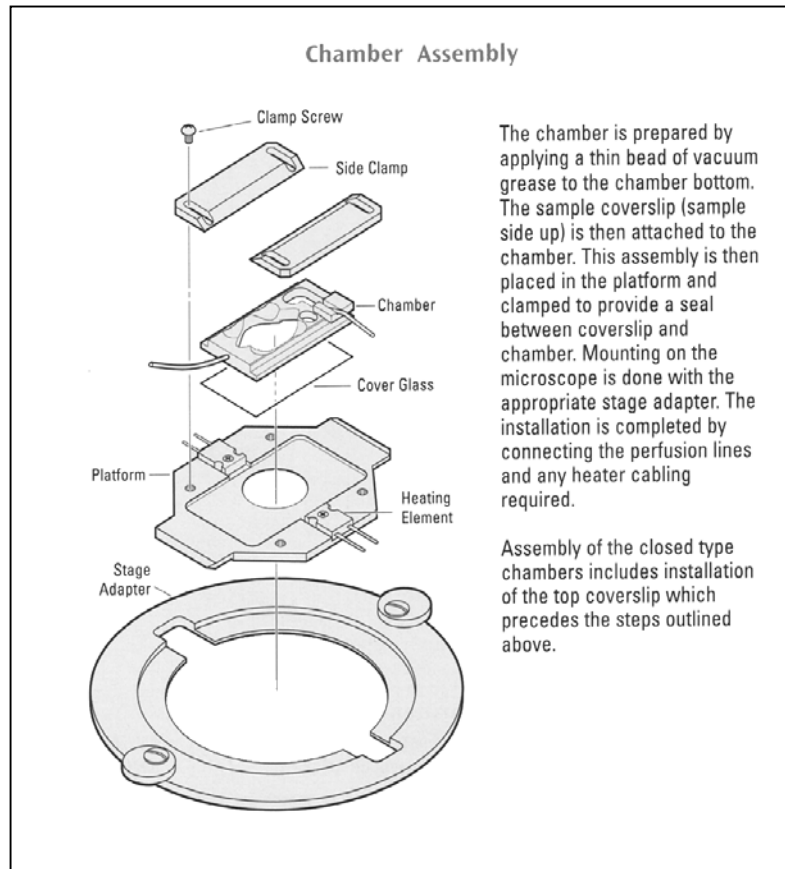

diameter glass coverslip onto the chamber bottom and gently pressing it into position. Remove and discard the spare coverslip. As before, inspect the chamber and remove any grease from the bath area and perfusion ports.

NOTE: You may wish to first test fit these coverslips to determine the best area to apply the grease bead.

5. The chamber is now primed to accept both top and bottom coverslips.

Installing the chamber bottom

1. Place the sample-containing coverslip (sample side up) into the provided recess on the *base of the platform* (this should be a P-5, PH-5, or PM-5 platform).
2. Check that the coverslip is seated properly and that the droplet of buffer covering the sample is centered on the coverslip.
3. Place the greased chamber into the platform and on top of the sample coverslip. Slide the platform side clamps into place and, if using a P-5 or PH-5 platform, tighten the assembly together using the 4 Phillips-head screws.

Pre-filling the perfusion lines

1. Perfusing solution is delivered through 1/16" OD polyethylene tubing which is attached to the inlet and exit ports.
2. Make attachments as described in the section labeled Perfusion and run a small amount of perfusate through both the inlet and exit ports. This will minimize the introduction of bubbles after the top coverslip is attached.

Installing the chamber top

1. Fill the bath area with solution prior to mounting the top coverslip into place. This can be achieved either by introducing perfusate through the inlet port or by pipetting directly into the bath area.
2. Using aspiration, remove any excess fluid from the greased coverslip/chamber interface. Take care to not disturb the grease seal.
3. Place a clean coverslip in the greased chamber top. The final seal is achieved by installing the retainer ring which is pressed into place. Be aware that the retainer should be oriented such that the small indentation around the outside of the retainer is towards the top. (This indentation facilitates removal of the retainer.)

Filling the chamber assembly

1. If the bath area is not completely filled, additional solution can be injected via the perfusion input port.
2. Air bubbles can be removed by applying suction with a syringe to the access tube adjacent to the input port.
3. Check the chamber for leaks.

Mounting onto the microscope

The assembled Series 20 chamber/platform can be mounted directly onto a microscope stage if the stage is both flat and has a cutout smaller than the platform. In most cases, however, the stage cutout

is larger than the platform necessitating the use of a stage adapter. In addition, a stage adapter is highly recommended if the platform is to be heated since it provides insulation between the platform and microscope stage.

Warner Instruments stocks stage adapters for most popular microscopes (see Appendix A) and we will custom manufacture adapters for special applications. Contact our Sales Department for details.

PERFUSION

Perfusate is delivered to the chamber through 1/16" OD polyethylene tubing (PE-160, available from Warner Instruments). A tubing sample is inserted into the chamber during shipping to identify the input port. Insertion of perfusion tubing to the input port can be greatly simplified by cutting the end of the tube on a bias rather than with a square face. We recommend pre-filling tubing with buffer before insertion as this will reduce the occurrence of bubbles in the flow path.

Fluid control

Solution source selection and rate of delivery can be of either of manual or automatic design and is left to the user. However, Warner Instruments manufactures several perfusion control systems (e.g., the valve-driven VC-6 and VC-8 Control Systems, both of which can be used for this application). Finally, a reference by Trese Leinders-Zufall describing the advantages of various perfusion control systems is available for download from the related files section of this product's page on our website. (You can find this and other references at http://www.warneronline.com/product_info.cfm?id=729)

Multiple perfusion solutions

Warner Instruments multi-port manifolds (MP Series) can be used to connect up to 8 solution lines to the Series 20 chambers. Input and output ports on the MP series manifolds are designed to accept PE-160 tubing. Tubing ends should be cut on an angle before insertion and pushed in as far as they will go. Air can be removed from each feed line by pre-filling with its appropriate solution. Finally, the manifold output tube is attached to the input port of the chamber. We recommend making the connection between the manifold exit port and chamber input port as short as possible to minimize solution exchange times.

Suction/Level control

Removal of solution from Series 20 chambers is usually performed by aspiration. We recommend the use of a vacuum trap to avoid introduction of aspirant into your house vacuum lines. In general, suction tubing is installed in a slot in the suction reservoir wall allowing adjustment of the fluid level in the main body of the chamber. Adjust the vacuum until the suction rate is equal to the flow rate into the chamber.

PLATFORM HEATING

A general discussion regarding issues surrounding heating of solutions and Warner platforms is available for download on our website. (http://www.warneronline.com/product_info.cfm?id=747)

Monitoring the heat

Heat is transferred to the aluminum platform from a pair of 20 Ω power resistors, one mounted on each side of the platform. Heater platforms are supplied with a thermistor assembly and non-heater platforms can be upgraded by ordering a CC-28 Cable Assembly. The temperature of the platform is monitored by measuring the platform thermistor resistance and adjusting the voltage to the heaters. A

second temperature sensing device, such as a thermistor, can be placed in the bath to directly monitor the solution temperature.

Automatic heat control is achieved by using either a Warner TC-324B or TC-344B Temperature Controller (single or dual channel models, respectively). These devices allow either the platform or solution thermistor to be selected as the control sensor. The desired temperature is set and automatically maintained at less than 1°C deviation.

Thermistor information

The maximum temperature rating of the supplied thermistor is 60°C. The thermistor assembly is inserted into the small hole drilled in the side of the platform.

NOTE: If the thermistor fits loosely in the hole, use a drop of oil (immersion or mineral), or alternatively vacuum grease, to insure good thermal transfer.

MAINTENANCE

Cleaning of polycarbonate chambers should be performed using a dilute detergent solution. Alternatively, Warner instruments has developed a trisodium phosphate (TSP) wash protocol which gives very good results. Contact our Technical Support staff or download the protocol in PDF format from our website. (http://www.warneronline.com/pdf/whitepapers/cleaning_plastic.pdf)

NOTE: Do not use alcohol, ether or other solvents on plastic parts. Solvents may be used on the anodized surfaces of the platforms. All chamber parts may be autoclaved.

APPENDIX

A. Warner Stage Adapters

Warner Instruments carries an extensive line of stage adapters for our Series 20 chambers and we are constantly adding new adapters as microscope manufacturers add to or modify their product lines. Please contact our offices if you do not find an adapter for your microscope in the list below. You may also want to check our website (http://www.warneronline.com/product_info.cfm?id=711) to see if an adapter has been added since this manual was printed.

	Manufacturer Microscope Model	Stage Adapter	Order No.
Nikon	Nikon Diaphot / TE200 / TE300 / TE2000	SA-NIK	64-0291
	Nikon TMS with 8x12 cm Cutout	SA-TMS/8	64-0292
	Nikon TMS with 9x13 cm Cutout	SA-TMS/9	64-0293
	Nikon E400 / E600 / E800	SA-20UU	64-0298
	Nikon Eclipse TS100	SA-TS100	64-0340
Olympus	Olympus IMT	SA-OLY	64-0294
	Olympus BX-40 / BX-50 / BX-51 / BX-61	SA-20UU	64-0298
	Olympus IMT-2 / IX-50 / IX-70 / IX-71 / IX-51 / IX-81 Burleigh Gibraltar Stainless Steel Stage	SA-OLY/2	64-0295
Leica	Leica-MicroSystems DMIL with Object Guide Leica-MicroSystems DMIRB/E with Plane Stage	SA-20LZ	64-0296
	Leica-MicroSystems DMIRB/E with 3-plate Mechanical Stage	SA-20L3P	64-0301
Zeiss	Zeiss Axiovert with 85x130 Mechanical Stage Zeiss Axiovert 100M, 200M	SA-20KZ	64-0297
	Zeiss Axiovert with 211x230 Specimen Stage Zeiss Axiovert 25, 35, 100, 200	SA-20LZ	64-0296
	Zeiss Axioskop with 75x30 Mechanical Stage Zeiss Axioskop LSM 510	SA-20UUZ	64-0336
	Zeiss with 3-plate Mechanical Stage	SA-20L3P	64-0301
Prior & Ludl	Prior & Ludl Motorized Stage on Upright Scope	SA-20PL	64-0299
	Prior & Ludl Motorized Stage on Inverted Scope	SA-20PLI	64-0300
HAI	HAI 900 Inverted Microscope	SA-HAI 900	64-0302
Burleigh Gibraltar	Burleigh Gibraltar Stainless Steel Stage	SA-OLY/2	64-0295
	Burleigh Gibraltar Aluminum Stage	SA-OLY/3	64-0386

NOTE: Warner Instrument **Series P** or **Series PH** platforms are designed to fit the Zeiss 76x26 microscope slide frame (#471719) without the use of a stage adapter. **All Series PM** platforms require a stage adapter. In general, all heater platforms work best with an insulating material between the platform and frame.

B. Chamber supplies/spare parts

We stock a large selection of supplies for use with Warner chambers. A partial listing of several parts are shown below. Please consult our catalog or website for items not included. Contact our Sales Department for special needs or prices.

Part Number	Order No.	Description	Qty/pkg
#1 Coverslips			
CS-15R	64-0703	15 mm diameter	100
Polyethylene Tubing			
PE-160/10	64-0755	0.045" x 0.062" (ID x OD) tubing (1.57mm x 1.14mm)	10 ft. (3.3 m)
PE-160/100	64-0756	0.045" x 0.062" (ID x OD) tubing (1.57mm x 1.14mm)	100 ft.(33 m)
Platforms			
P-5	64-0281	P-5 platform for Series 20 chambers, non-heater	1
PH-5	64-0288	PH-5 platform for Series 20 chambers, heater	1
PM-5	64-1564	PM-5 Chamber platform with magnetic clamps	1
Replacement/Spare Parts for Heater Platforms			
CC-28	64-0106	Heater Cable Assembly	1
TS-60P	64-0269	Replacement Control Thermistor	1
TS-70B	64-0276	Replacement Monitor Thermistor	1
Multi-Perfusion Zero Dead Space Manifolds			
MP-2	64-0206	2 input, 1 output	1
MP-3	64-0207	3 input, 1 output	1
MP-4	64-0208	4 input, 1 output	1
MP-5	64-0209	5 input, 1 output	1
MP-6	64-0210	6 input, 1 output	1
MP-8	64-0211	8 input, 1 output	1
Accessories			
111-Kit	64-0378	Silicone Lubricant Kit	1

C. Comments

- 1) Best temperature regulation is achieved by preheating your solution with an in-line heater (e.g. Warner Fast-flow SH-27B or Slow-flow SF-28) in addition to directly warming the chamber platform.

D. Specifications

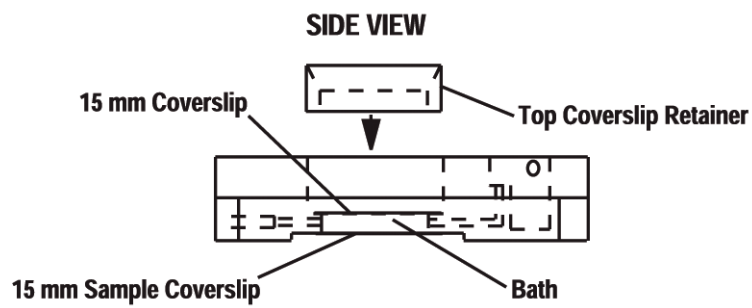
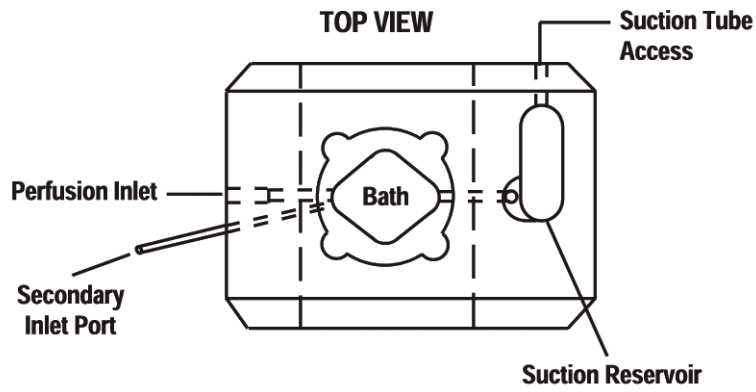

BATH DIMENSIONS

Volume: 36 μ l

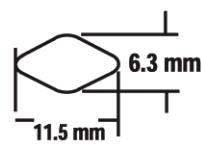

RC-20

Volume: 70 μ l

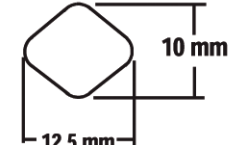

RC-20H

Volumes for 1 mm solution height