

SERIES 20 CHAMBERS

A feature in common with all Series 20 chambers is the use of a glass coverslip for the floor of the chamber. In most cases, this same coverslip contains the imaging sample. When viewed with inverted microscopes, images are visualized through a single thickness of glass, usually 0.13-0.17 mm.

THE RC-21BRFS CHAMBER

The **RC-21BRFS** is a closed bath imaging chamber incorporating field stimulation electrodes. A pair of platinum wires is epoxied into the parallel sides of the oval shaped bath and the connecting wires terminate in 1 mm pins. The chamber is sealed on both the top and bottom with 25 mm round coverslips. The bath volume of the completed assembly is 260 μ l.

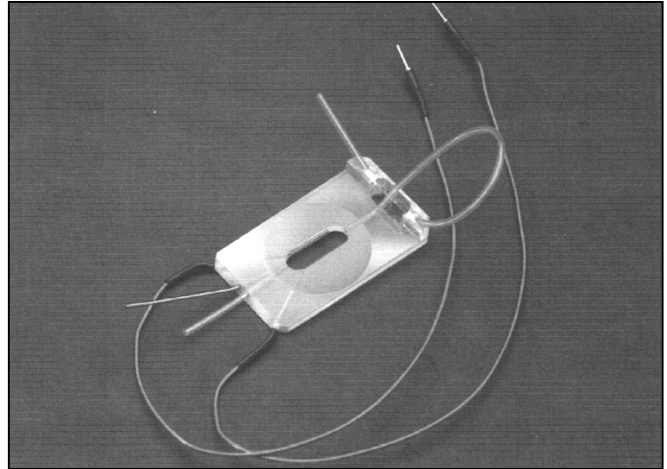

The chamber features an injection port adjacent to the bath solution input port for direct introduction of substances or removal of bubbles. The chamber also features a back-pressure control on the solution output port.

ASSEMBLY

A general procedure for the assembly of a Series 20 chamber is to first apply a coverslip to the chamber bottom and then place the assembly in the appropriate platform. The platform serves to (1) clamp the assembly together providing a tight seal between the chamber and coverslip and (2) provide a means to mount the chamber onto the microscope stage, usually via a microscope specific adapter plate. The **RC-21BRFS** differs from this procedure in that there is an additional coverslip mounted on the top of the chamber to provide an enclosed volume.

Prior to beginning assembly make sure all required components are available and thoroughly cleaned. Be sure to remove any old vacuum grease from the perfusion channels and input/output ports. To aid in application, pre-load a 1 cc syringe with a small quantity of vacuum grease. A syringe needle is not necessary.

Preparing the chamber to accept the coverslips

- A) Using the 1 cc syringe, apply a small bead of grease around the seat which the top coverslip rests upon. Place the appropriate coverslip into the chamber top and gently press it into position to evenly distribute the grease around the seat.

- B) Remove and discard the used coverslip. Clean away any grease which may have entered the bath area. Pay particular attention to the perfusion input and outlet ports since the presence of grease in these areas will impede the flow of perfusate.
- C) Using the 1 cc syringe, apply a small bead of grease to the coverslip groove on the *bottom of the chamber*. Evenly distribute the grease around the seat by placing appropriate glass coverslip onto the chamber bottom and gently pressing it into position. Remove and discard this coverslip. As before, inspect the chamber and remove any grease from the bath area and perfusion ports.

NOTE: You may wish to first test fit coverslips into place to determine the best area to apply the grease bead.

- D) The chamber is now primed to accept both top and bottom coverslips.

Installing the chamber bottom

- A) Place the sample-containing coverslip (sample side up) into the provided recess on the *bottom of the chamber*.
- B) Check that the coverslip is seated properly and that the droplet of buffer covering the sample is centered on the coverslip.
- C) Place the partially assembled chamber into the platform (this should be a **P-2** or **PH-2** platform).

Pre-filling the perfusion lines

- A) The perfusing solution is delivered through 1/16" OD polyethylene tubing which is attached to the inlet and exit ports.
- B) Make attachments as described in the section labeled Perfusion and run a small amount of perfusate through both the inlet and exit ports. This will reduce the introduction of bubbles after the top coverslip is attached.

Installing the chamber top

- A) Prior to placing the top coverslip into place, fill the bath area with solution. This can be achieved either by introducing perfusate through the inlet port or by pipetting directly into the bath area.
- B) Using aspiration, remove any excess fluid from the greased coverslip/chamber interface. Take care to not disturb the grease seal.
- C) Place a clean coverslip in the greased chamber top. The final seal is achieved by mounting the platform top. Tighten using the 4 Phillips head screws.

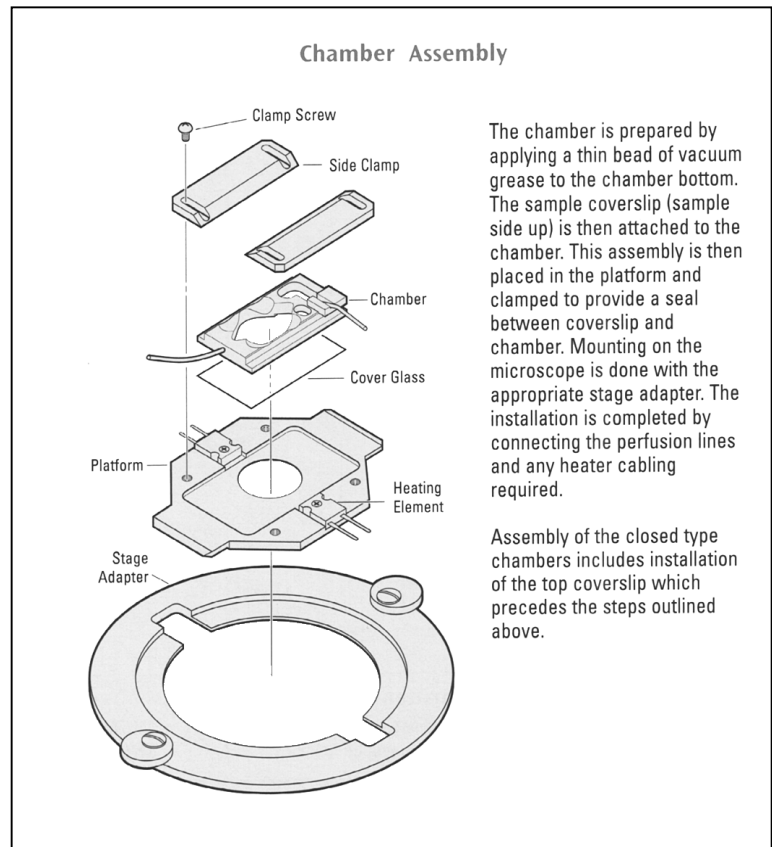

Filling the chamber assembly

- A) If the bath area is not completely filled, additional solution can be injected via the perfusion input port.
- B) Air bubbles can be removed by applying suction with a syringe to the metal access tube next to the input port.
- C) Check the chamber for leaks.

Attaching the electrode leads

- A) Attach the green electrode leads to the assembled chamber/platform prior to mounting it to the microscope.

NOTE: Use care when connecting the green wire leads to the chamber body. The contacts within the plug are fragile.

- B) Once the platform is mounted to the microscope stage you can make further attachment to your electronics.

Mounting onto the microscope

The assembled Series 20 chamber/platform can be mounted directly onto a microscope stage if the stage is both flat and has a cutout smaller than the platform. In most cases, however, the stage cutout is larger than the platform necessitating the use of a stage adapter. In addition, a stage adapter is highly recommended if the platform is to be heated since it provides insulation between the platform and microscope stage.

Warner Instruments stocks stage adapters for most popular microscopes (see Appendix A) and we will custom manufacture adapters for special applications. Contact our Sales Department for details.

PERFUSION

Perfusate is delivered to the chamber through 1/16" OD polyethylene tubing (**PE-160**, available from Warner Instruments). A tubing sample is inserted into the chamber during shipping to identify the input port. Insertion of perfusion tubing to the input port can be greatly simplified by cutting the end of the tube on a bias rather than with a square face. We recommend pre-filling tubing with buffer before insertion as this will reduce the occurrence of bubbles in the flow path.

Fluid control

Solution source selection and rate of delivery can be of either of manual or automatic design and is left to the user. However, Warner Instruments manufactures several perfusion control systems (e.g., the valve-driven **VC-6** and **VC-6M** Control Systems, both of which can be used for this application). Finally, a reference by Trese Leinders-Zufall describing the advantages of various perfusion control systems is available for download from the Support section of our website. You can find this and other references at <http://www.warneronline.com/techref.html>.

Multiple perfusion solutions

Warner Instruments multi-port manifolds (**MP Series**) can be used to connect up to 8 solution lines to the **Series 20** chambers. Input and output ports on the **MP series** manifolds are designed to accept **PE-160** tubing. Tubing ends should be cut on an angle before insertion and pushed in as far as they will go. Air can be removed from each feed line by pre-filling with its appropriate solution. Finally, the

manifold output tube is attached to the input port of the chamber. We recommend making the connection between the manifold exit port and chamber input port as short as possible to minimize solution exchange times.

Suction/Level control

Removal of solution from Series 20 chambers is usually performed by aspiration. We recommend the use of a vacuum trap to avoid introduction of aspirant into your house vacuum lines. In general, suction tubing is installed in a slot in the suction reservoir wall allowing adjustment of the fluid level in the main body of the chamber. Adjust the vacuum until the suction rate is equal to the flow rate into the chamber.

PLATFORM HEATING

A general discussion regarding issues surrounding heating of solutions and Warner platforms is available for download on our website. (<http://www.warneronline.com.techrefs.html>)

Monitoring the heat

Heat is transferred to the aluminum platform from a pair of 20 Ω power resistors, one mounted on each side of the platform. Heater platforms are supplied with a thermistor assembly and non-heater platforms can be upgraded by ordering a **CC-28 Cable Assembly**. The temperature of the platform is monitored by measuring the platform thermistor resistance and adjusting the voltage to the heaters. A second temperature sensing device such as a thermistor should be placed in the bath to directly monitor the solution temperature.

Automatic heat control is achieved by using either a Warner **TC-324** or **TC-344** Temperature Controller (single or dual channel models, respectively). These devices allow either the platform or solution thermistor to be selected as the control sensor. The desired temperature is set and automatically maintained at less than 1°C deviation.

Thermistor information

The maximum temperature rating of the supplied thermistor is 60°C. The thermistor assembly is inserted into the small hole drilled in the side of the platform.

NOTE: If the thermistor fits loosely in the hole, use a drop of oil (immersion or mineral), or alternatively vacuum grease, to insure good thermal transfer.

MAINTENANCE

Cleaning of polycarbonate chambers should be performed using a dilute detergent solution. Alternatively, Warner instruments has developed a trisodium phosphate (TSP) wash protocol which gives very good results. Contact our Technical Support staff or download the protocol in PDF format from our website. (<http://www.warneronline.com/techref.html>)

NOTE: Do not use alcohol, ether or other solvents on plastic parts. Solvents may be used on the anodized surfaces of the platforms. All chamber parts may be autoclaved.

APPENDIX

A. Warner Stage Adapters

Warner Instruments carries an extensive line of stage adapters for our Series 20 chambers and we are constantly adding new adapters as microscope manufacturers add to or modify their product lines. Please contact our offices if you do not find an adapter for your microscope in the list below. You may also want to check our website (<http://www.warneronline.com>) to see if an adapter has been added since this manual was printed.

Microscope Manufacturer	Warner Instrument Stage Adapter Model No.
Nikon Diaphot, TE 200 & TE 300	SA-NIK
Nikon TMS with 8 x 12 cm stage cutout	SA-TMS/8
Nikon TMS with 9 x 13 cm stage cutout	SA-TMS/9
Nikon E400, E600, and E800 Olympus BX-40 and BX-50 Zeiss Axioskop	SA-20UU
Olympus IMT (older model)	SA-OLY
Olympus IMT-2, IX-50 and IX-70 Burleigh Gebraltar	SA-OLY/2
Zeiss Axiovert with 211x230 specimen stage Leica (Leitz) DMIRB/E with plane stage Leica (Leitz) DMIL with object guide	SA-20LZ
Leica (Leitz) DMIRB/E with 3-plate mechanical stage	SA-20L3P
Prior and Ludl motorized stages on upright Prior and Ludl motorized stages on inverted	SA-20PL SA-20PLI

NOTE: Warner Instrument **Series P** platforms are designed to fit the Zeiss 76x26 microscope slide frame (#471719) without a stage adapter. Heater platforms will require an insulating material between the platform and frame.

B. Chamber supplies/spare parts

We stock a large selection of supplies for use with Warner chambers. A partial listing of several parts are shown below. Please consult our catalog or website for items not included. Contact our Sales Department for special needs or prices.

Part Number	Description	Qty/pkg
#1 Coverslips		
CS-12R	12 mm diameter (for RC-25 chamber)	100
CS-15R	15 mm diameter (for RC-25F chamber)	100
CS-22S	22 x 22 mm square (for RC-21B chamber)	100
CS-25R	25 diameter (for RC-21R chamber)	100
CS-22/40	22 x 40 mm rectangle (for RC-21, 21A, 22, 22C, 23, 23D, 24, 24E, 26 & 26G chambers)	50
CS-22/50	22 x 50 mm rectangle (for RC-26Z chamber)	50
CS-24/50	24 x 50 mm rectangle (for RC-27, 27E, 27L, 28 and 29 chambers)	50
Polyethylene Tubing		
PE-160/10	0.062"ODx0.045"ID tubing (1.57mm x 1.14mm)	10 ft. (3.3 m)
PE-160/100	0.062"ODx0.045"ID tubing (1.57mm x 1.14mm)	100 ft. (33 m)
Replacement/Spare Parts for Heater Platforms		
CC-28	Heater Cable Assembly	1
TS-60P	Probe Thermistor	1
Multi-Perfusion Zero Dead Space Manifolds		
MP-2	2 input, 1 output	1
MP-3	3 input, 1 output	1
MP-4	4 input, 1 output	1
MP-5	5 input, 1 output	1
MP-6	6 input, 1 output	1
MP-7	7 input, 1 output	1
MP-8	8 input, 1 output	1
Accessories		
111	Silicone Lubricant	1

C. Comments

- 1) Best temperature regulation is achieved by preheating your solution with an in-line heater (Warner **Fast-flow SH-27B** or **Slow-flow SF-28**) in addition to directly warming the chamber platform.