

SERIES 20 CHAMBERS

A feature in common with all Series 20 chambers is the use of a glass coverslip for the floor of the chamber. In most cases, this same coverslip contains the imaging sample. When viewed with inverted microscopes, images are visualized through a single thickness of glass, usually 0.13-0.17 mm. (#1)

The design of the Series 20 chambers incorporates a diamond-shaped bath which has been shown to produce a laminar flow across the bath. Since bath volumes are generally small, exchange times are measured in seconds even when flow rates are less than 1 ml/min.

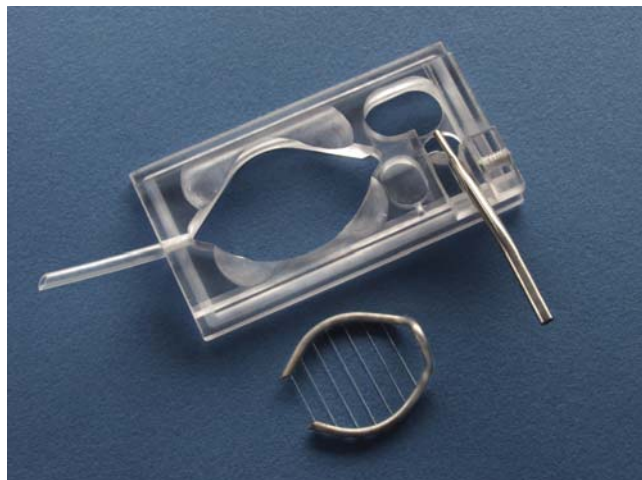

THE RC-26 AND RC-26G CHAMBERS

The RC-26 and RC-26G chambers are large volume, open bath chambers which will accommodate large specimens such as slice preparations and permit excellent access for electrodes. The larger bath allows coverslips to be inserted into the top of the chamber and removed at the end of the experiment. While samples can be placed directly onto the chamber bottom, the RC-26 and RC-26G will accept 12 mm and 15 mm diameter coverslips, respectively. The working volume of the RC-26 and RC-26G is 150 and 180 μ l, respectively. The bottom coverslip is 22 x 40 mm for both models.

Optional hold-down anchors (termed harps) are available for both models. Harps are stainless steel with Lycra® threads. Thread spacing is 2 mm and anchors weigh 500 mg. Other thread spacings are available. Contact our Sales department.

ASSEMBLY

The general procedure for assembling Series 20 chambers is to first mount a coverslip to form the chamber bottom and then placing the assembly into the appropriate platform. The platform serves to (1) clamp the assembly together providing a tight seal between the chamber and coverslip, and (2) to provide a means to mount the chamber/platform assembly onto the microscope, usually via a stage adapter.

Application of vacuum grease

Vacuum grease can be applied to Warner chambers by use of a syringe or a small artist's dotting brush. Both approaches are described below.

NOTE: Prior to beginning assembly make sure all required components are available and thoroughly cleaned. Be sure to remove any old vacuum grease from the perfusion channels and input/output ports.

Brush technique

The brush technique is performed in a similar manner as described above except that the vacuum grease is applied using a #1 or #2 artist's dotting brush. Brushes can be found in your local art shop, university bookstore, or can be purchased from Warner.

NOTE: We suggest the brush technique since the resultant application of vacuum grease is more precise.

Syringe technique

Begin by loading a 1cc syringe with a small quantity of vacuum grease. The use of a needle is unnecessary and undesirable.

Using the syringe, apply a small bead of grease to the chamber as described below. Evenly distribute the grease by placing a spare coverslip into place and gently pressing it into position.

Remove and discard the spare coverslip and clean away any grease which may have entered the bath area. Pay particular attention to the perfusion input and outlet ports since the presence of grease in these areas will impede the flow of perfusate.

Assembling the chamber

1. Using the brush or the 1 cc syringe, apply a small bead of grease to the coverslip groove on the *bottom of the chamber*.
2. Evenly distribute the grease around the seat by placing a 22 x 40 mm rectangular glass coverslip onto the chamber bottom and gently pressing it into position.
3. Remove and discard the coverslip.
4. Inspect the chamber and remove any grease from the bath area and perfusion ports.
5. The chamber is now primed and ready to accept the bottom coverslip.

NOTE: You may wish to first test fit a coverslip to determine the best amount of grease to apply.

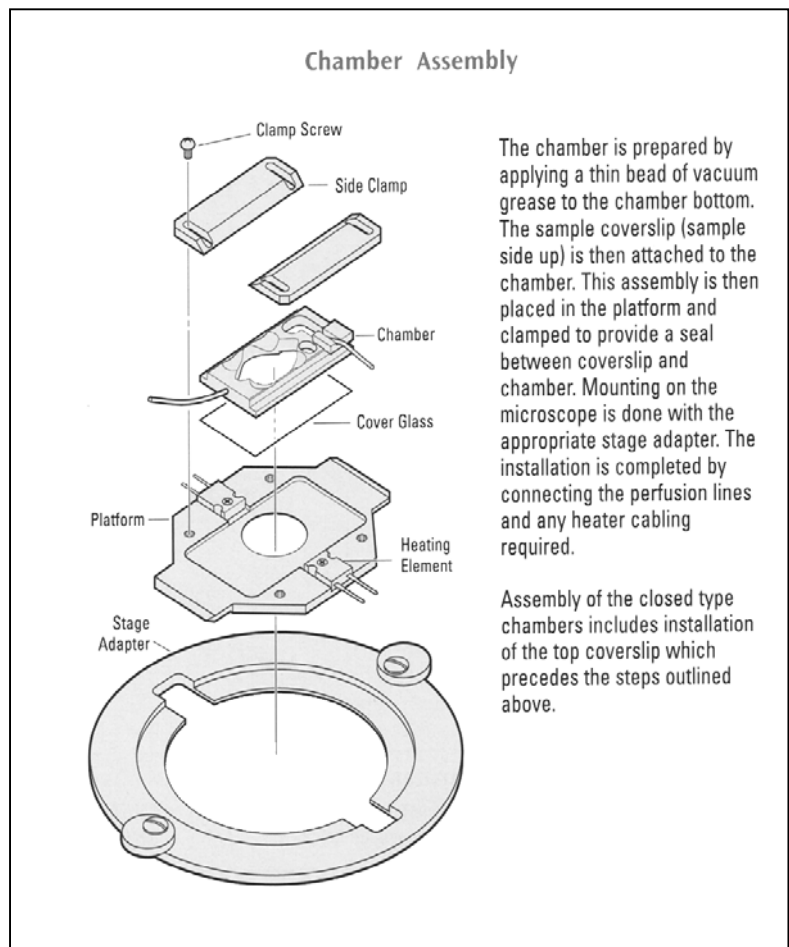

Installing the chamber bottom and mounting into the platform

1. Place a clean 22 x 40 mm coverslip onto the *bottom of the chamber* and gently press it into place to form a secure attachment. Take care to avoid breaking the coverslip or smearing vacuum grease over the 'window' area.
2. Check that the coverslip is seated properly and that the perfusion ports are not occluded.
3. Place the chamber/coverslip assembly into a P-1, PH-1 or PM-1 platform.
4. Slide the platform side clamps into place and, if using a P-1 or PH-1, tighten the assembly together using the 4 Phillips-head screws.

Pre-filling the perfusion lines

1. Perfusing solution is delivered through 1/16" OD polyethylene tubing which is attached to the inlet port.
2. Make attachments to the chamber as described in the section labeled 'Perfusion' and run a small amount of perfusate through both the inlet and exit ports.

Mounting onto the microscope

The assembled Series 20 chamber/platform can be mounted directly onto a microscope stage if the stage is both flat and has a cutout smaller than the platform. In most cases, however, the stage cutout is larger than the platform necessitating the use of a stage adapter. In addition, a stage adapter is highly recommended if the platform is to be heated since it provides insulation between the platform and microscope stage.

Warner Instruments stocks stage adapters for most popular microscopes (see Appendix A) and we will custom manufacture adapters for special applications. Contact our Sales Department for details.

PERFUSION

Perfusate is delivered to the chamber through 1/16" OD polyethylene tubing (PE-160, available from Warner Instruments). A tubing sample is inserted into the chamber during shipping to identify the input port. Insertion of perfusion tubing to the input port can be greatly simplified by cutting the end of the tube on a bias rather than with a square face. We recommend pre-filling tubing with buffer before insertion as this will reduce the occurrence of bubbles in the flow path.

Fluid control

Solution source selection and rate of delivery can be of either of manual or automatic design and is left to the user. However, Warner Instruments manufactures several perfusion control systems (e.g., the valve-driven VC-6 and VC-8 Control Systems, both of which can be used for this application). Finally, a reference by Trese Leinders-Zufall describing the advantages of various perfusion control systems is available for download from the related files section of this product's page on our website. You can find this and other references at http://www.warneronline.com/product_info.cfm?id=736.

Multiple perfusion solutions

Warner Instruments multi-port manifolds (MP Series) can be used to connect up to 8 solution lines to the Series 20 chambers. Input and output ports on the MP series manifolds are designed to accept PE-160 tubing. Tubing ends should be cut on an angle before insertion and pushed in as far as they will go. Air can be removed from each feed line by pre-filling with its appropriate solution. Finally, the

manifold output tube is attached to the input port of the chamber. We recommend making the connection between the manifold exit port and chamber input port as short as possible to minimize solution exchange times.

Suction/Level control

Removal of solution from Series 20 chambers is usually performed by aspiration. We recommend the use of a vacuum trap to avoid introduction of aspirant into your house vacuum lines. In general, suction tubing is installed in a slot in the suction reservoir wall allowing adjustment of the fluid level in the main body of the chamber. Adjust the vacuum until the suction rate is equal to the flow rate into the chamber.

PLATFORM HEATING

A general discussion regarding issues surrounding heating of solutions and Warner platforms is available for download on our website. (http://www.warneronline.com/product_info.cfm?id=747)

Monitoring the heat

Heat is transferred to the aluminum platform from a pair of 20 Ω power resistors, one mounted on each side of the platform. Heater platforms are supplied with a thermistor assembly and non-heater platforms can be upgraded by ordering a **CC-28 Cable Assembly**. The temperature of the platform is monitored by measuring the platform thermistor resistance and adjusting the voltage to the heaters. A second temperature sensing device, such as a thermistor, can be placed in the bath to directly monitor the solution temperature.

Automatic heat control is achieved by using either a Warner TC-324B or TC-344B Temperature Controller (single or dual channel models, respectively). These devices allow either the platform or solution thermistor to be selected as the control sensor. The desired temperature is set and automatically maintained at less than 1°C deviation.

Thermistor information

The maximum temperature rating of the supplied thermistor is 60°C. The thermistor assembly is inserted into the small hole drilled in the side of the platform.

NOTE: If the thermistor fits loosely in the hole, use a drop of oil (immersion or mineral), or alternatively vacuum grease, to insure good thermal transfer.

MAINTENANCE

Cleaning of polycarbonate chambers should be performed using a dilute detergent solution. Alternatively, Warner instruments has developed a trisodium phosphate (TSP) wash protocol which gives very good results. Contact our Technical Support staff or download the protocol in PDF format from our website. (http://www.warneronline.com/pdf/whitepapers/cleaning_plastic.pdf)

NOTE: Do not use alcohol, ether or other solvents on plastic parts. Solvents may be used on the anodized surfaces of the platforms. All chamber parts may be autoclaved.

APPENDIX

A. Warner Stage Adapters

Warner Instruments carries an extensive line of stage adapters for our Series 20 chambers and we are constantly adding new adapters as microscope manufacturers add to or modify their product lines. Please contact our offices if you do not find an adapter for your microscope in the list below. You may also want to check our website (http://www.warneronline.com/product_info.cfm?id=711) to see if an adapter has been added since this manual was printed.

	Manufacturer Microscope Model	Stage Adapter	Order No.
Nikon	Nikon Diaphot / TE200 / TE300 / TE2000	SA-NIK	64-0291
	Nikon TMS with 8x12 cm Cutout	SA-TMS/8	64-0292
	Nikon TMS with 9x13 cm Cutout	SA-TMS/9	64-0293
	Nikon E400 / E600 / E800	SA-20UU	64-0298
	Nikon Eclipse TS100	SA-TS100	64-0340
Olympus	Olympus IMT	SA-OLY	64-0294
	Olympus BX-40 / BX-50 / BX-51 / BX-61	SA-20UU	64-0298
	Olympus IMT-2 / IX-50 / IX-70 / IX-71 / IX-51 / IX-81 Burleigh Gibraltar Stainless Steel Stage	SA-OLY/2	64-0295
Leica	Leica-MicroSystems DMIL with Object Guide Leica-MicroSystems DMIRB/E with Plane Stage	SA-20LZ	64-0296
	Leica-MicroSystems DMIRB/E with 3-plate Mechanical Stage	SA-20L3P	64-0301
Zeiss	Zeiss Axiovert with 85x130 Mechanical Stage Zeiss Axiovert 100M, 200M	SA-20KZ	64-0297
	Zeiss Axiovert with 211x230 Specimen Stage Zeiss Axiovert 25, 35, 100, 200	SA-20LZ	64-0296
	Zeiss Axioskop with 75x30 Mechanical Stage Zeiss Axioskop LSM 510	SA-20UUZ	64-0336
	Zeiss with 3-plate Mechanical Stage	SA-20L3P	64-0301
Prior & Ludl	Prior & Ludl Motorized Stage on Upright Scope	SA-20PL	64-0299
	Prior & Ludl Motorized Stage on Inverted Scope	SA-20PLI	64-0300
HAI	HAI 900 Inverted Microscope	SA-HAI 900	64-0302
Burleigh Gibraltar	Burleigh Gibraltar Stainless Steel Stage	SA-OLY/2	64-0295
	Burleigh Gibraltar Aluminum Stage	SA-OLY/3	64-0386

NOTE: Warner Instrument **Series P** or **Series PH** platforms are designed to fit the Zeiss 76x26 microscope slide frame (#471719) without the use of a stage adapter. **All Series PM** platforms require a stage adapter. In general, all heater platforms work best with an insulating material between the platform and frame.

B. Chamber supplies/spare parts

We stock a large selection of supplies for use with Warner chambers. A partial listing of several parts are shown below. Please consult our catalog or website for items not included. Contact our Sales Department for special needs or prices.

Part Number	Order No.	Description	Qty/pkg
#1 Coverslips			
CS-22/40	64-0707	22 mm x 40 mm rectangle (for RC-21, 21A, 22, 22C, 23, 23D, 24, 24E, 26 & 26G chambers)	50
Polyethylene Tubing			
PE-160/10	64-0755	0.045" x 0.062" (ID x OD) tubing (1.57mm x 1.14mm)	10 ft. (3.3 m)
PE-160/100	64-0756	0.045" x 0.062" (ID x OD) tubing (1.57mm x 1.14mm)	100 ft.(33 m)
Platforms			
P-1	64-0277	P-1 platform for Series 20 chambers, non-heater	1
PH-1	64-0284	PH-1 platform for Series 20 chambers, heater	1
PM-1	64-1526	PM-1 Chamber platform with magnetic clamps	1
Replacement/Spare Parts for Heater Platforms			
CC-28	64-0106	Heater Cable Assembly	1
TS-60P	64-0269	Replacement Control Thermistor	1
TS-70B	64-0276	Replacement Monitor Thermistor	1
Multi-Perfusion Zero Dead Space Manifolds			
MP-2	64-0206	2 input, 1 output	1
MP-3	64-0207	3 input, 1 output	1
MP-4	64-0208	4 input, 1 output	1
MP-5	64-0209	5 input, 1 output	1
MP-6	64-0210	6 input, 1 output	1
MP-8	64-0211	8 input, 1 output	1
Accessories			
111-Kit	64-0378	Silicone Lubricant Kit	1

C. Comments

- 1) Best temperature regulation is achieved by preheating your solution with an in-line heater (e.g., Warner Fast-flow SH-27B or Slow-flow SF-28) in addition to directly warming the chamber platform.

D. Specifications

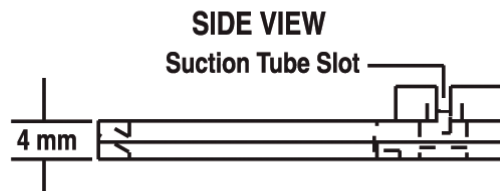
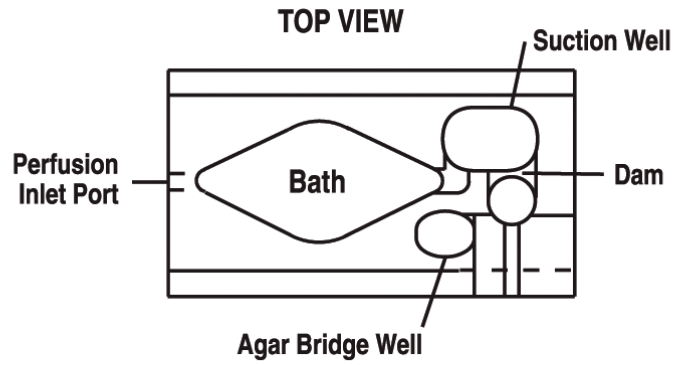

BATH DIMENSIONS

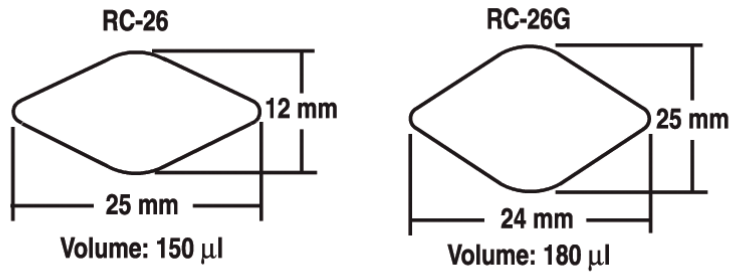

Volumes are for 1 mm solution height