

SERIES 20 CHAMBERS

A feature in common with all Series 20 chambers is the use of a glass coverslip for the floor of the chamber. In most cases, this same coverslip contains the imaging sample. When viewed with inverted microscopes, images are visualized through a single thickness of glass, usually 0.13-0.17 mm.

THE RC-27 CHAMBER

The **RC-27** chamber features a rectangular bath rather than the diamond shape more common to chambers from Warner Instruments. This design allows the **RC-27** to accommodate large specimens, or the insertion of coverslips (up to 12 x 24 mm) typical of organotypic slice culture studies, while still producing a uniform solution flow across the chamber. The chamber has an adjustable spreader plate at the bath input and the bottom is formed by a 24 x 50 mm coverslip.

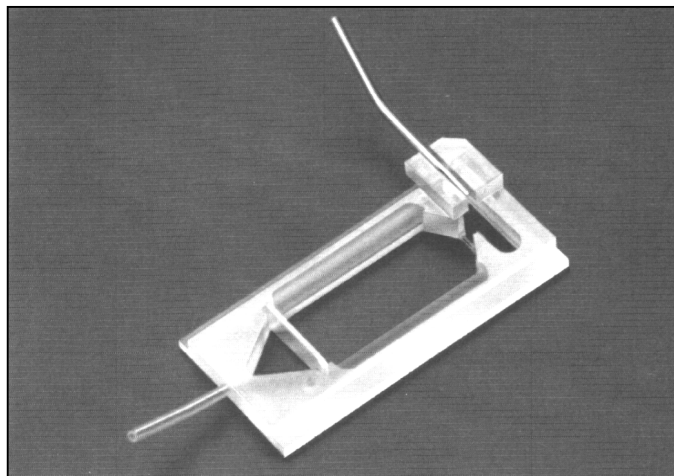

ASSEMBLY

The general procedure for assembling Series 20 chambers is to first apply the coverslip to form the chamber bottom and then placing the partial assembly into the appropriate platform. The platform serves to (1) clamp the assembly together providing a tight seal between the chamber and coverslip, and (2) to provide a means to mount the chamber/platform assembly onto the microscope, usually via a stage adapter.

Prior to beginning assembly make sure all required components are available and thoroughly cleaned. Be sure to remove any old vacuum grease from the perfusion channels and input/output ports. To aid in application, pre-load a 1 cc syringe with a small quantity of vacuum grease. A syringe needle is not necessary.

Preparing the chamber to accept the coverslips

- A) Using the 1 cc syringe, apply a small bead of grease to the coverslip groove on the *bottom of the chamber*.
- B) Evenly distribute the grease around the seat by placing a 24 x 50 mm rectangular glass coverslip onto the chamber bottom and gently pressing it into position.
- C) Remove and discard the coverslip.
- D) Inspect the chamber and remove any grease from the bath area and perfusion ports.
- E) The chamber is now primed and ready to accept the bottom coverslip.

NOTE: You may wish to first test fit a coverslip to determine the best amount of grease to apply.

Installing the chamber bottom and mounting into the platform

- A) Place a clean 24 x 50 mm coverslip onto the *bottom of the chamber* and gently press it into place to form a secure attachment. Take care to avoid breaking or smearing vacuum grease over the 'window' portion of the coverslip.
- B) Check that the coverslip is seated properly and that the perfusion ports are not occluded.
- C) Place the chamber/coverslip assembly into a **P-6** or **PH-6** platform.
- D) Slide the platform side clamps into place and tighten the assembly together using the 4 Phillips-head screws.

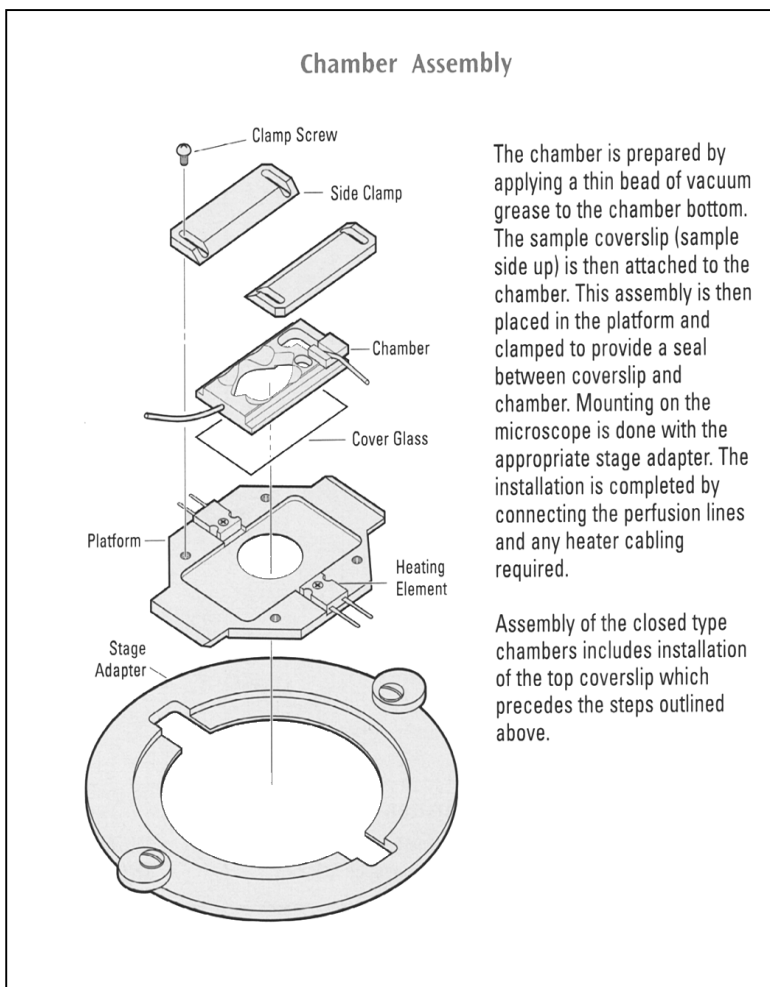

The chamber is prepared by applying a thin bead of vacuum grease to the chamber bottom. The sample coverslip (sample side up) is then attached to the chamber. This assembly is then placed in the platform and clamped to provide a seal between coverslip and chamber. Mounting on the microscope is done with the appropriate stage adapter. The installation is completed by connecting the perfusion lines and any heater cabling required.

Assembly of the closed type chambers includes installation of the top coverslip which precedes the steps outlined above.

Pre-filling the perfusion lines

- A) Perfusing solution is delivered through 1/16" OD polyethylene tubing which is attached to the inlet port.
- B) Make attachments to the chamber as described in the section labeled 'Perfusion' and run a small amount of perfusate through both the inlet and exit ports.

Mounting onto the microscope

The assembled Series 20 chamber/platform can be mounted directly onto a microscope stage if the stage is both flat and has a cutout smaller than the platform. In most cases, however, the stage cutout is larger than the platform necessitating the use of a stage adapter. In addition, a stage adapter is highly recommended if the platform is to be heated since it provides insulation between the platform and microscope stage.

Warner Instruments stocks stage adapters for most popular microscopes (see Appendix A) and we will custom manufacture adapters for special applications. Contact our Sales Department for details.

PERFUSION

Perfusate is delivered to the chamber through 1/16" OD polyethylene tubing (**PE-160**, available from Warner Instruments). A tubing sample is inserted into the chamber during shipping to identify the input port. Insertion of perfusion tubing to the input port can be greatly simplified by cutting the end of the tube on a bias rather than with a square face. We recommend pre-filling tubing with buffer before insertion as this will reduce the occurrence of bubbles in the flow path.

Fluid control

Solution source selection and rate of delivery can be of either of manual or automatic design and is left to the user. However, Warner Instruments manufactures several perfusion control systems (e.g., the valve-driven **VC-6** and **VC-6M** Control Systems, both of which can be used for this application). Finally, a reference by Trese Leinders-Zufall describing the advantages of various perfusion control systems is available for download from the Support section of our website. You can find this and other references at <http://www.warneronline.com>.

Multiple perfusion solutions

Warner Instruments multi-port manifolds (**MP Series**) can be used to connect up to 8 solution lines to the **Series 20** chambers. Input and output ports on the **MP series** manifolds are designed to accept **PE-160** tubing. Tubing ends should be cut on an angle before insertion and pushed in as far as they will go. Air can be removed from each feed line by pre-filling with its appropriate solution. Finally, the manifold output tube is attached to the input port of the chamber. We recommend making the connection between the manifold exit port and chamber input port as short as possible to minimize solution exchange times.

Suction/Level control

Removal of solution from Series 20 chambers is usually performed by aspiration. We recommend the use of a vacuum trap to avoid introduction of aspirant into your house vacuum lines. In general, suction tubing is installed in a slot in the suction reservoir wall allowing adjustment of the fluid level in the main body of the chamber. Adjust the vacuum until the suction rate is equal to the flow rate into the chamber.

PLATFORM HEATING

A general discussion regarding issues surrounding heating of solutions and Warner platforms is available for download on our website. (<http://www.warneronline.com>)

Monitoring the heat

Heat is transferred to the aluminum platform from a pair of 20 Ω power resistors, one mounted on each side of the platform. Heater platforms are supplied with a thermistor assembly and non-heater platforms can be upgraded by ordering a **CC-28 Cable Assembly**. The temperature of the platform is monitored by measuring the platform thermistor resistance and adjusting the voltage to the heaters. A second temperature sensing device such as a thermistor should be placed in the bath to directly monitor the solution temperature.

Automatic heat control is achieved by using either a Warner **TC-324** or **TC-344** Temperature Controller (single or dual channel models, respectively). These devices allow either the platform or solution thermistor to be selected as the control sensor. The desired temperature is set and automatically maintained at less than 1°C deviation.

Thermistor information

The maximum temperature rating of the supplied thermistor is 60°C. The thermistor assembly is inserted into the small hole drilled in the side of the platform. **NOTE: If the thermistor fits loosely in the hole, use a drop of oil (immersion or mineral), or alternatively vacuum grease, to insure good thermal transfer.**

MAINTENANCE

Cleaning of polycarbonate chambers should be performed using a dilute detergent solution. Alternatively, Warner instruments has developed a trisodium phosphate (TSP) wash protocol which gives very good results. Contact our Technical Support staff or download the protocol in PDF format from our website. (<http://www.warneronline.com>)

NOTE: Do not use alcohol, ether or other solvents on plastic parts. Solvents may be used on the anodized surfaces of the platforms. All chamber parts may be autoclaved.

APPENDIX

A. Warner Stage Adapters

Warner Instruments carries an extensive line of stage adapters for our Series 20 chambers and we are constantly adding new adapters as microscope manufacturers add to or modify their product lines. Please contact our offices if you do not find an adapter for your microscope in the list below. You may also want to check our website (<http://www.warneronline.com>) to see if an adapter has been added since this manual was printed.

Microscope Manufacturer	Warner Instrument Stage Adapter Model No.
Nikon Diaphot, TE 200 & TE 300	SA-NIK
Nikon TMS with 8 x 12 cm stage cutout	SA-TMS/8
Nikon TMS with 9 x 13 cm stage cutout	SA-TMS/9
Nikon E400, E600, and E800 Olympus BX-40 and BX-50 Zeiss Axioskop	SA-20UU
Olympus IMT (older model)	SA-OLY
Olympus IMT-2, IX-50 and IX-70 Burleigh Gebraltar	SA-OLY/2
Zeiss Axiovert with 211x230 specimen stage Leica (Leitz) DMIRB/E with plane stage Leica (Leitz) DMIL with object guide	SA-20LZ
Leica (Leitz) DMIRB/E with 3-plate mechanical stage	SA-20L3P
Prior and Ludl motorized stages on upright Prior and Ludl motorized stages on inverted	SA-20PL SA-20PLI

NOTE: Warner Instrument Series P platforms are designed to fit the Zeiss 76x26 microscope slide frame (#471719) without a stage adapter. Heater platforms will require an insulating material between the platform and frame.

B. Chamber supplies/spare parts

We stock a large selection of supplies for use with Warner chambers. A partial listing of several parts are shown below. Please consult our catalog or website for items not included. Contact our Sales Department for special needs or prices.

Part Number	Description	Qty/pkg
#1 Coverslips		
CS-12R	12 mm diameter (for RC-25 chamber)	100
CS-15R	15 mm diameter (for RC-25F chamber)	100
CS-22S	22 x 22 mm square (for RC-21B chamber)	100
CS-25R	25 diameter (for RC-21R chamber)	100
CS-22/40	22 x 40 mm rectangle (for RC-21, 21A, 22, 22C, 23, 23D, 24, 24E, 26 & 26G chambers)	50
CS-22/50	22 x 50 mm rectangle (for RC-26Z chamber)	50
CS-24/50	24 x 50 mm rectangle (for RC-27, 27E, 27L, 28 and 29 chambers)	50
Polyethylene Tubing		
PE-160/10	0.062"ODx0.045"ID tubing (1.57mm x 1.14mm)	10 ft. (3.3 m)
PE-160/100	0.062"ODx0.045"ID tubing (1.57mm x 1.14mm)	100 ft. (33 m)
Replacement/Spare Parts for Heater Platforms		
CC-28	Heater Cable Assembly	1
TS-60P	Probe Thermistor	1
Multi-Perfusion Zero Dead Space Manifolds		
MP-2	2 input, 1 output	1
MP-3	3 input, 1 output	1
MP-4	4 input, 1 output	1
MP-5	5 input, 1 output	1
MP-6	6 input, 1 output	1
MP-7	7 input, 1 output	1
MP-8	8 input, 1 output	1
Accessories		
111	Silicone Lubricant	1

C. Comments

- 1) Best temperature regulation is achieved by preheating your solution with an in-line heater (Warner **Fast-flow SH-27B** or **Slow-flow SF-28**) in addition to directly warming the chamber platform.