

## Special comments for wicking RC-27L and RC-29 chambers

This slice support platform has been re-engineered to allow improved solution flow both above and below the grid support. This improvement is achieved by the use of two wicks, one each for upper and lower solution flows. Solution from each flow pathway is drawn by the respective wick into the perfusion outflow chamber where it is removed by the suction tube.

Wicks can be made from two-ply tissue, folded single-ply tissue, or any other wicking material which fits into the outflow pathway. We recommend that you experiment to find the material which best suits your application.

The lower wick should fit neatly into the outflow channel on the underside of the slice support platform. It should be aligned with the edge of the slice grid cutout on the upstream side and protrude into the perfusion outflow chamber on the downstream side.

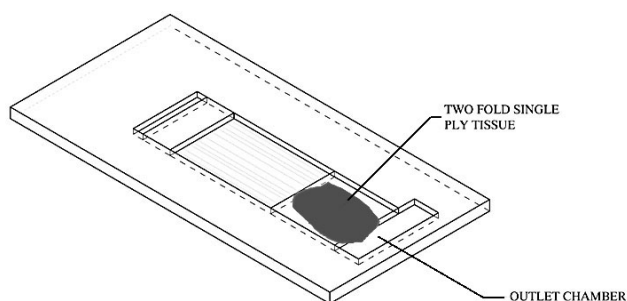

The upper wick should simply span the dam separating the bath chamber from the perfusion outflow chamber.

