

The **RC-27D** and **RC-27LD** chambers have been designed especially for researchers planning to maintain a tight optical focus on a specimen while simultaneously performing multiple solution changes.

These chambers are hybrids incorporating the same large-bath as the **RC-27L** coupled with the same ultra-quiet perfusion input as our **JG Series** chambers. The large imaging field allows for maximal observation of biological specimens with the added benefit of a sloped input.

In general, the unique chamber input eliminates vibrations associated with solution exchange that could

cause specimens or optical fields

to fluctuate during imaging and recording. This approach allows for very smooth solution delivery. I-V perfusion lines can be used to deliver drops at a fixed rate to the chamber without introducing noise into the specimen field. In addition, multiplexed solution delivery is possible without the potential of solution switching artifacts.

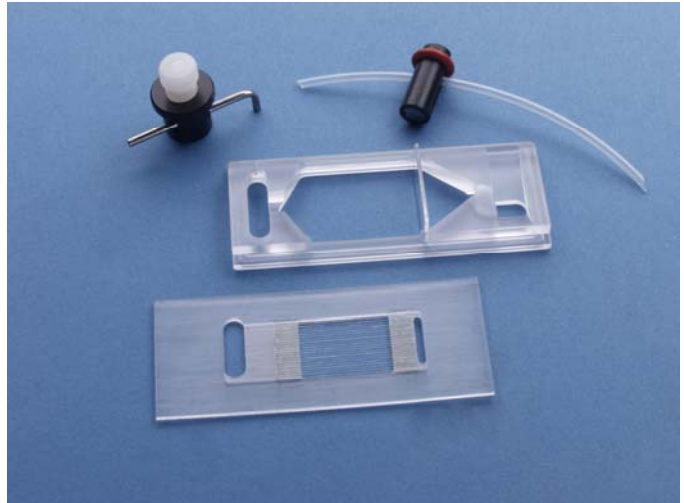

THE RC-27D CHAMBER

The RC-27D features a rectangular bath rather than the diamond-shape bath more common to chambers from Warner Instruments. This design allows the chamber to accommodate large specimens while still producing a uniform solution flow. The chamber has an adjustable spreader plate at the bath input and the bottom is formed by a 24 x 50 mm coverslip. This chamber uses the PM-7 platform.

THE RC-27LD CHAMBER

The RC-27LD chamber carries the same geometry as the RC-27D and is designed for slice studies where solution flow to both the top and bottom of the preparation is desired. This additional capability is achieved by an arrangement of slice support and slice hold-down to hold and position the sample.

The slice rests on a support 0.5 mm above the coverslip floor and is fixed in place by slice anchor hold down (commonly termed a 'harp'). Both support and harp use Lycra® thread to secure the slice while allowing maximum access to the preparation. Thread spacing is 1 mm on the slice support and 2 mm on the anchor. This chamber uses the PM-7D platform.

ASSEMBLY

The general procedure for assembling the RC-27D is to use a coverslip to form the chamber bottom, and then to place the completed assembly into an appropriate platform. The platform serves to (1) clamp the assembly together providing a tight seal between the chamber and coverslip, and (2) to provide a means to mount the chamber/platform assembly onto the microscope, usually via a stage adapter.

The assembly of the **RC-27LD** differs from the procedure described above in that there is the additional step of mounting the slice support between the coverslip and chamber body. (This extra step is most simply achieved by first pre-mounting the slice support to the bottom coverslip and then mounting the two components as a single unit).

Prior to beginning assembly make sure all required components are available and thoroughly cleaned. Be sure to remove any old vacuum grease from perfusion channels and input/output ports. To aid in application, use a small artist's dotting brush available from any art supply store or from Warner Instruments.

Pre-assemble the slice support to the bottom coverslip (RC-27LD only)

- A) Place the slice support on a clean surface oriented so that the supporting Lycra® threads are facing down. (i.e., the bottom of the slice support is facing up.)
- B) Using the brush, apply a small coating of grease around the perimeter of the slice support.
- C) Evenly distribute the grease by placing a 24 x 50 mm rectangular glass coverslip onto the slice support and gently pressing it into position.
- D) Remove and discard this coverslip.
- E) Clean away any excess vacuum grease and mount a new, clean 24 x 50 mm coverslip onto the slice support.
- F) Inspect the quality of the seal between the slice support and coverslip and place aside for later use.

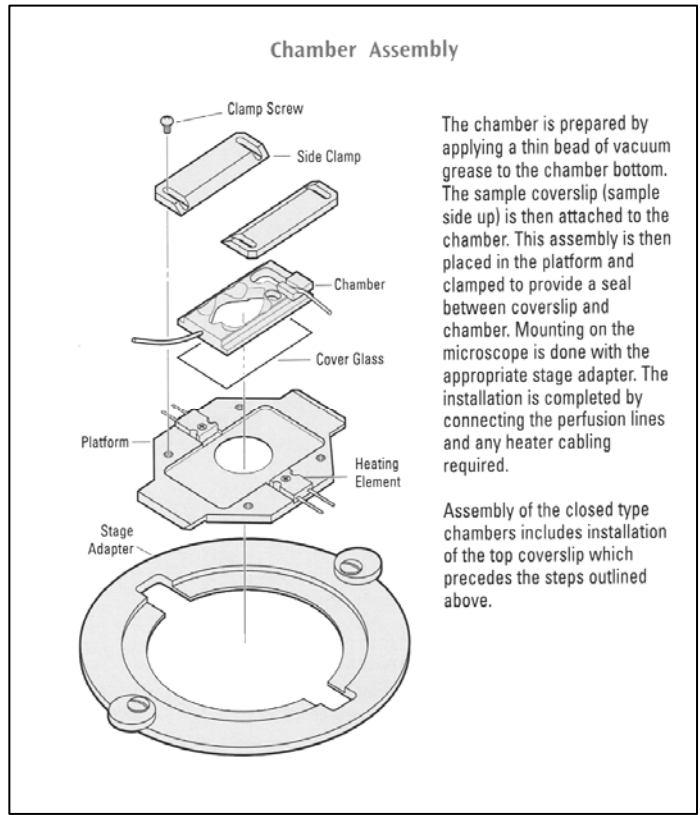

Preparing the chamber to accept the coverslips (all models)

- A) Using the brush, apply a thin coating of grease to the coverslip seat on the *bottom of the chamber*.

NOTE: You may wish to first test fit a coverslip to determine the best amount of grease to apply.
- B) Evenly distribute the grease around the seat by placing a 22x40 mm rectangular glass coverslip onto the chamber bottom and gently pressing it into position.
- C) Remove and discard this coverslip.
- D) Inspect the chamber and remove any grease from the bath area and perfusion ports.
- E) The chamber is now primed and ready to accept the bottom coverslip.

Installing the chamber bottom

- A) Place the bottom coverslip (or previously assembled slice support/chamber bottom assembly) onto the *bottom of the chamber* and gently press it into place to form a secure attachment. Take care to avoid breaking the coverslip or smearing vacuum grease over the 'window' area.
- G) Check that the perfusion flow channels are not occluded.
- H) Place the completed chamber assembly into a **PM-7D** platform.
- I) Slide the platform side clamps into position and secure the chamber into place.

Pre-filling the perfusion lines

- A) Perfusing solution is delivered through 1/16" OD polyethylene (PE) tubing. If using multiplexed solution delivery, pre-fill each line as this will reduce the occurrence of bubbles in the flow path.

Mounting onto a microscope

The chamber/platform assembly can be mounted directly onto a microscope stage if the stage is both flat and has a cutout smaller than the platform diameter. In most cases, however, the stage cutout is larger than the platform necessitating the use of a stage adapter.

In addition, a stage adapter is highly recommended if platform heating will be used since an adapter provides insulation between the platform and microscope stage. Warner Instruments stocks stage adapters for most popular microscopes (see Appendix A) and we can custom manufacture adapters for special applications. Contact us for details.

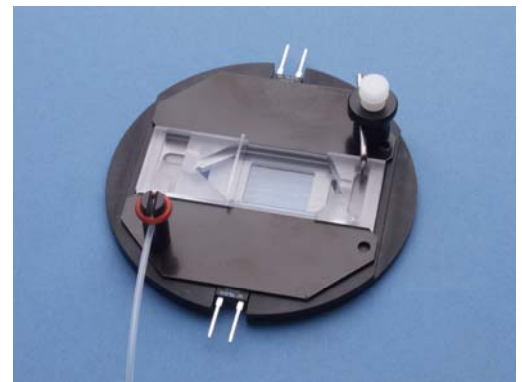

PERFUSION

Input

Perfusate is delivered to the chamber through 1/16" OD polyethylene (PE) tubing. The basic setup is shown to the right. Place your perfusion input line into the holder and secure with the rubber o-ring. Position the assembly such that the outflow drips smoothly onto the input bath ramp.



Suction/Level control

Removal of solution is performed by aspiration. Perfusate is removed from the chamber through a stainless steel (SS) tube which connects to 1/16" OD polyethylene (PE) tubing. In general, the SS aspirator is held in position by a magnetic clamp allowing adjustment of the fluid level in the main body of the chamber. Adjust (1) the height of the aspirator and (2) the vacuum pressure until the suction rate is equal to the flow rate into the chamber.

Note: We recommend the use of a vacuum trap to avoid introduction of aspirant into your house vacuum lines.

Fluid control

Solution selection and rate of delivery can be of either of manual or automatic design and is left to the user. However, Warner Instruments manufactures several perfusion control systems (e.g., the valve-driven, VC

Series Perfusion Control Systems) which are optimized for this task. Finally, a reference by Trese Leinders-Zufall describing the advantages of various perfusion systems is available for download from the Support section of our website.

Multiple perfusion solutions

Multi-port (MP Series) manifolds can be used to connect up to 8 solution lines to Warner chambers. Input and output ports on the MP series manifolds are designed to accept PE-160 tubing. Tubing ends should be cut on an angle before insertion and pushed in as far as they will go. Air can be removed from each feed line by pre-filling with its appropriate solution. Finally, the manifold output tube is positioned above the sloped input of the chamber.

MAGNETIC CLAMPS

Magnetic clamps provide a convenient method of mounting or positioning tools around a chamber. The clamping wings of the PM-7 and PM-7D platforms are designed to facilitate the application of a wide variety of magnetic tools including aspirator suction lines, gas jets, perfusion tubes, ground electrodes, hold down needles, and bath thermistor probes.

PLATFORM HEATING

A general discussion regarding issues surrounding heating of solutions and Warner platforms is available for download on our website. (<http://www.warneronline.com>)

Monitoring the heat

Heat is transferred to the aluminum platform from a pair of 20 Ω power resistors, one mounted on each side of the platform. The temperature of the platform is monitored by measuring the platform thermistor resistance and adjusting the voltage to the heaters. A second temperature sensing device, such as a monitor thermistor, should be placed in the bath to directly sense the solution temperature.

Automatic heat control is achieved by using either a Warner TC-324 or TC-344 Temperature Controller (single or dual channel models, respectively). The desired temperature is set and automatically maintained at less than 1°C deviation.

Thermistor information

The maximum temperature rating of the thermistors supplied with Warner temperature controllers is 60°C.

NOTE: The white feedback thermistor is inserted into the small hole drilled into the **side of the platform**. If this thermistor fits loosely, use a drop of oil (immersion or mineral), or alternatively vacuum grease, to insure good thermal transfer.

MAINTENANCE

Cleaning of polycarbonate chambers should be performed using a dilute detergent solution. Alternatively, Warner instruments has developed a trisodium phosphate (TSP) wash protocol which gives very good results. Download the protocol in PDF format from the Support section of our website.

NOTE: Do not use alcohol, ether or other solvents on plastic parts. Solvents may be used on the anodized surfaces of the platforms. All chamber parts may be autoclaved.

APPENDIX

A. Warner Stage Adapters

Warner Instruments carries an extensive line of stage adapters for our Series 20 chambers and we are constantly adding new adapters as microscope manufacturers add to or modify their product lines. Please contact our offices if you do not find an adapter for your microscope in the list below. You may also want to check our website (<http://www.warneronline.com>) to see if an adapter has been added since this manual was printed.

Microscope Manufacturer	Model No.	Catalog number
Nikon Diaphot, TE 200 & TE 300	SA-NIK	64-0322
Nikon TMS with 8 x 12 cm stage cutout	SA-TMS/8	64-0323
Nikon TMS with 9 x 13 cm stage cutout	SA-TMS/9	64-0224
Nikon E400, E600, and E800 Olympus BX-40 and BX-50 Zeiss Axioskop	SA-20JU	64-0298
Olympus IMT (older model)	SA-OLY	64-0294
Olympus IMT-2, IX-50 and IX-70 Burleigh Gebraltar	SA-OLY/2	64-0325
Zeiss Axiovert with 211x230 specimen stage Leica (Leitz) DMIRB/E with plane stage Leica (Leitz) DMIL with object guide	SA-20LZ	64-0296
Leica (Leitz) DMIRB/E with 3-plate mechanical stage	SA-20L3P	64-0328
Prior and Ludl motorized stages on upright Prior and Ludl motorized stages on inverted	SA-20PL SA-20PLI	64-0299 64-0300

B. Chamber supplies/spare parts

We stock a large selection of supplies for use with Warner chambers. A partial listing of several parts are shown below. Please consult our catalog or website for items not included. Contact our Sales Department for special needs or prices.

Part Number	Catalog number	Description	Qty/pkg
#1 Coverslips			
CS-22/40	64-0707	22 x 40 mm rectangle (for RC-21, 21A, 22, 22C, 23, 23D, 24, 24E, 26 & 26G chambers)	50
Polyethylene Tubing			
PE-160/10	64-0755	0.062"ODx0.045"ID tubing (1.57mm x 1.14mm)	10 ft. (3.3 m)
PE-160/100	64-0756	0.062"ODx0.045"ID tubing (1.57mm x 1.14mm)	100 ft. (33 m)
Replacement/Spare Parts for Heater Platforms			
CC-28	64-0106	Heater Cable Assembly	1
TS-60P	64-0269	Probe Thermistor	1
Multi-Perfusion Zero Dead Space Manifolds			
MP-2	64-0206	2 input, 1 output	1
MP-3	64-0207	3 input, 1 output	1
MP-4	64-0208	4 input, 1 output	1
MP-5	64-0209	5 input, 1 output	1
MP-6	64-0210	6 input, 1 output	1
MP-8	64-0211	8 input, 1 output	1
Accessories			
111-Kit	64-0275	Silicone Applicator Kit	1
111	64-0378	Silicone Lubricant	1

C. Comments

- 1) Best temperature regulation is achieved by preheating your solution with an in-line solution heater (e.g., Warner Fast-flow SH-27B or Slow-flow SF-28) in addition to directly warming the chamber platform.