

WARNER IMAGING CHAMBERS

A feature in common with all Warner chambers is the use of a glass coverslip as the floor of the chamber. In most cases, this same coverslip contains the imaging sample. When viewed with an inverted microscope, images are visualized through a glass thickness of 0.13-0.17 mm. (#1)

THE RC-30 CHAMBER

The RC-30 is a low profile chamber incorporating special features for confocal imaging. These features include user defined bath geometry and volume and a large viewing area. A #1 glass coverslip forms both the top and bottom of the chamber allowing it to be inverted in the mounting platform facilitating its use with both inverted and upright microscopes. An optional heater model is available.

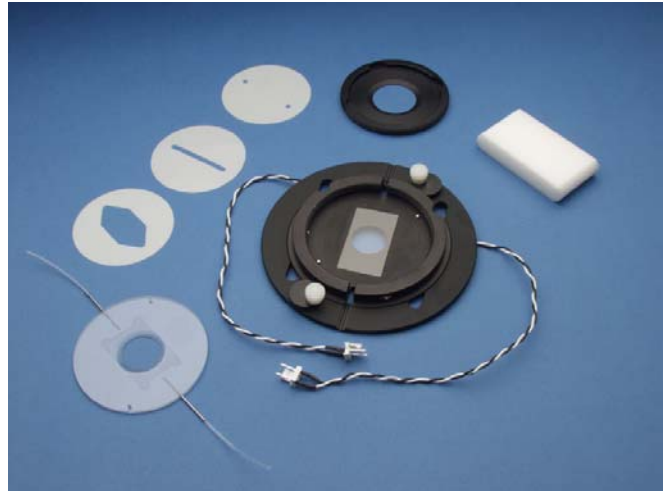

Variable Bath Volume/Fast Exchange - The side walls of the chamber bath is formed with a silicone gasket sandwiched between the top and bottom coverslips. Wall height (or spacing between the coverslips) can range from 250-1000 μm and is defined by the thickness of the gasket used. Blank gaskets are supplied with the chamber permitting the development of the customized bath geometry required for your application. In addition, pre-cut gaskets are also supplied with the chamber; one cut wide to allow full use of the aperture window (17.7 mm diameter) and a narrow, slotted version for fast solution exchange.

Large Viewing Area - The viewing aperture in the chamber housing is 17.7 mm in diameter. The chamber bottom is beveled to permit maximum access to the bottom coverslip.

Reversible - The chamber can be mounted in the stage adapter to accommodate both upright and inverted microscopes.

Optional Heater Version - Model RC-30HV includes a pair of resistive heater elements mounted to the chamber base. Heaters are compatible with Warner TC-324B and TC-344B Heater Controllers.

ASSEMBLY

The general procedure for assembling the RC-30 is to first secure a coverslip to the platform **COVERSLIP TOP PLATE**. This is followed by mounting the **CHAMBER FORMING GASKET** onto the **COVERSLIP TOP PLATE**. Next, a sample containing coverslip is mounted onto **PLATFORM BASE**. Finally, the various components are assembled resulting in a sealed, single unit. The assembled chamber can then be mounted onto the microscope, usually via a stage adapter.

Please refer to the exploded view on the next page when following the RC-30 assembly instructions described below.

1. Begin by mounting a 20x30 mm coverslip onto the COVERSIP TOP PLATE. Locate the 22x30 mm indentation on the underside of the COVERSIP TOP PLATE and apply a thin film of vacuum grease to this indentation. Secure a clean 22x30 mm coverslip into place making sure there is no excess grease.

NOTE: Total coverage is not important since the grease only serves to hold the coverslip in place during the assembly process and provides no sealing.

2. Next, secure the CHAMBER FORMING GASKET to the underside of the COVERSIP TOP PLATE.

Select the gasket to be used and remove the polyethylene cover from the side which will face the COVERSIP TOP PLATE. Position the gasket so that the perfusion inlet and outlet ports, as well as the alignment holes, are centered as shown in the sketch at the bottom of this page. Press the chamber forming gasket into place. The silicone gasket material should make a clean seal with the plastic coverslip top plate. Take a moment to press out any trapped air bubbles.

3. Carefully remove the polyethylene cover from the exposed bottom of the gasket taking care to not disturb the existing seal.
4. Locate the 22x40 mm indentation on the PLATFORM BASE. As described above, apply a thin film of vacuum grease to this indentation and secure your culture containing coverslip into place. Leave a small drop of buffer on the coverslip to cover your sample.
5. Place the COVERSIP TOP PLATE with the attached gasket into the PLATFORM BASE aligning the two holes in the plate with the corresponding pins in the base. Check for proper fit.
6. Screw the PRESSURE PLATE onto the assembly and tighten with the PRESSURE PLATE WRENCH. Check the quality of the assembly by gently wiggling the stainless steel perfusion ports on the TOP COVERSIP PLATE. There should be no movement.

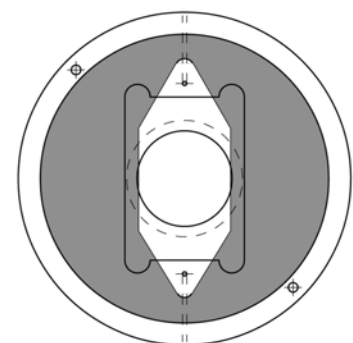
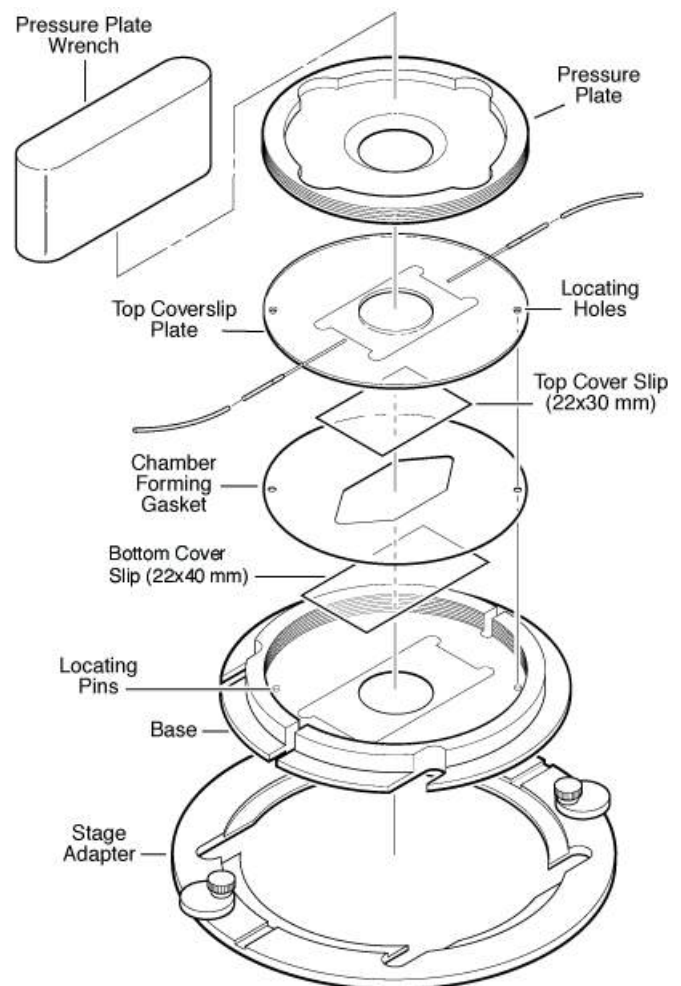

7. Connect a perfusion line to the chamber input and completely fill the bath with solution. Tilting the chamber while filling will help avoid the occurrence of trapped air pockets. Once the chamber is filled, wipe away any excess moisture and place the chamber onto a flat surface. Check for leaks and re-tighten the PRESSURE PLATE if necessary.
8. Once the chamber has been verified to be water-tight, it may be mounted onto the microscope. Connect the perfusion inlet and outlet tubes before mounting the chamber to avoid spilling solution on the microscope optics.

Mounting onto the microscope

The RC-30 chamber can be mounted directly onto a microscope stage if the stage is both flat and has a cutout which fits the platform. In most cases, however, the stage cutout is larger than the platform necessitating the use of a stage adapter. Warner Instruments stocks stage adapters for most popular microscopes (see Appendix A) and we will custom manufacture adapters for special applications. Contact our Sales Department for details.

PERFUSION

Perfusate is delivered to the chamber through the supplied PE-90 tubing. We recommend pre-filling all perfusion lines before attachment to reduce the occurrence of bubbles in the flow path.

NOTE: PE-90 tubing will fit neatly inside PE-160 tubing. This allows the RC-30 chamber to be used with an in-line heater such as the SH-27B.

Fluid control

The selection of solution sources and rate of delivery can be of either manual or automatic design and is left to the user. However, Warner Instruments manufactures several perfusion control systems (such as the valve-driven VC-6 and VC-8 Control Systems) all of which can be used with this application.

The rate of solution delivery can be of a pumped or gravity feed design. While these approaches allow control of the flow rate, Warner Instruments also offers a dedicated solution flow regulator (Model FR-50 Flow Regulator).

Finally, a reference by Trese Leinders-Zufall describing the advantages of different perfusion control systems is available for download from the related files section of this product's page on our website http://www.warneronline.com/product_info.cfm?id=774.

Multiple perfusion solutions

Warner Instruments multi-port manifolds (MM or ML Series) can be used to connect up to 8 solution lines to the RC-30 chamber. Air should be removed from each feed line by pre-filling with its appropriate solution. The manifold output tube is attached to the input port of the chamber. We recommend making the connection between the manifold and chamber as short as possible to minimize solution exchange times.

PLATFORM HEATING

A general discussion regarding issues surrounding heating of solutions and Warner platforms is available for download on our website. (http://www.warneronline.com/product_info.cfm?id=747)

Monitoring the heat

Heat is transferred to the aluminum platform from a pair of 20 Ω power resistors, one mounted on each side of the platform. Heater platforms are supplied with a thermistor assembly and non-heater platforms can be upgraded by ordering a CC-28 Cable Assembly. The temperature of the platform is monitored by measuring the platform thermistor resistance and adjusting the voltage to the heaters. A second temperature sensing device, such as a thermistor, can be placed in the bath to directly monitor the solution temperature.

Automatic heat control is achieved by using either a Warner TC-324B or TC-344B Temperature Controller (single or dual channel models, respectively). These devices allow either the platform or solution thermistor to be selected as the control sensor. The desired temperature is set and automatically maintained at less than 1°C deviation.

Thermistor information

The maximum temperature rating of the supplied thermistor is 60°C. The thermistor assembly is attached to the underside of the platform.

NOTE: A drop of oil (immersion or mineral), or alternatively vacuum grease, can be used to insure good thermal transfer.

MAINTENANCE

Cleaning of the COVERSIP TOP PLATE should be performed using a dilute detergent solution. Alternatively, Warner instruments has developed a trisodium phosphate (TSP) wash protocol which is effective in cleaning plastic parts. Contact our Technical Support staff or download the protocol in PDF format from our website. (http://www.warneronline.com/pdf/whitepapers/cleaning_plastic.pdf)

NOTE: Do not use alcohol, ether or other solvents on plastic parts. Solvents may be used on the anodized surfaces of the platforms. Aluminum chamber parts may be autoclaved.

APPENDIX

A. Warner Stage Adapters

Warner Instruments carries an extensive line of stage adapters for our Series 30 chambers and we are constantly adding new adapters as microscope manufacturers add to or modify their product lines. Please contact our offices if you do not find an adapter for your microscope in the list below. You may also want to check our website (http://www.warneronline.com/product_info.cfm?id=1358) to see if an adapter has been added since this manual was printed.

Manufacturer	Microscope Model	Stage Adapter	Order Number
Nikon	Nikon Diaphot/TE200/TE300/TE2000	SA-30NIK	64-0322
	Nikon TMS with 9 x 13 cm Cut-Out	SA-30TMS/9	64-0324
	Nikon E400/E600/E800 Stage	SA-30UU	64-0380
Olympus	Olympus IMT-2/IX-50/IX-70/BX-50WI	SA-30/OLY2	64-0325
Leica	Leica Galvo Z Inverted Stage	SA-30GALVZi	64-1456
	Leica Dmirb/E with 3-Plate Mechanical Stage	SA-30L3P	64-0328
	Leica Galvo Z Upright Stage	SA-30GALVOZ	64-0377
Prior & Ludl	Prior & Ludl Motorized Stage	SA-30PLI	64-0329
Zeiss	Zeiss Axiovert 211 x 230	SA-30LZ	64-0326
	Zeiss LSM510 Stage	SA-30UUZ	64-0379
	Zeiss Axiovert 85 x 130 Mechanical (K) Stage	SA-30KZ	64-0327

NOTE: Warner Instrument Series P or Series PH platforms are designed to fit the Zeiss 76x26 microscope slide frame (#471719) without the use of a stage adapter. All Series PM platforms require a stage adapter. In general, all heater platforms work best with an insulating material between the platform and frame.

B. Chamber supplies/spare parts

We stock the following supplies for your convenience. Contact our Sales Department for prices.

Part Number	Order No.	Description	Qty/pkg
#1 Coverslips			
CS-22/30	64-0706	Rectangular cover glass, 22 mm x 30 mm, #1 thickness	50
CS-22/40	64-0707	Rectangular cover glass, 22 mm x 40 mm, #1 thickness	50
Polyethylene Tubing			
PE-160/10	64-0755	0.045" x 0.062" (ID x OD) tubing (1.57mm x 1.14mm)	10 ft. (3.3 m)
PE-160/100	64-0756	0.045" x 0.062" (ID x OD) tubing (1.57mm x 1.14mm)	100 ft.(33 m)
PE-90/10	64-0754	0.97 mm x 0.58 mm (ID x OD) tubing	10 ft. (3.3 m)
Replacement/Spare Parts for Heater Platforms			
CC-28	64-0106	Heater Cable Assembly	1
TS-60P	64-0269	Replacement Control Thermistor	1

TS-70B	64-0276	Replacement Monitor Thermistor	1
RH-2	64-0274	Heater elements	2
Optional and replacement gaskets			
GS-30L/10	64-0330	Large bath gasket, 250 µm thick	10
GS-30L/15	64-0331	Large bath gasket, 375 µm thick	10
GS-30S/10	64-0332	Slotted bath gasket, 250 µm thick	10
GS-30S/15	64-0333	Slotted bath gasket, 375 µm thick	10
GS-30B/10	64-0334	Blank gasket, 250 µm thick	10
GS-30B/15	64-0335	Blank gasket, 375 µm thick	10
GS-30B/4	64-0341	Blank gasket, 100 µm thick	10
GS-30L/4	64-0342	Large bath gasket, 100 µm thick	10
GS-30S/4	64-0343	Slotted bath gasket, 100 µm thick	10
Multi-Perfusion Zero Dead Space Manifolds			
MM-2	64-0203	2 input, 1 output	1
MM-4	64-0204	4 input, 1 output	1
MM-6	64-0205	6 input, 1 output	1
ML-2	64-0200	2 input, 1 output	1
ML-4	64-0201	4 input, 1 output	1
ML-6	64-0202	6 input, 1 output	1
ML-8	64-0199	8 input, 1 output	1
Accessories			
111-Kit	64-0378	Silicone Lubricant Kit	1

C. Comments

- 1) Silicone vacuum grease (also called stopcock grease) is available from Warner Instruments (Warner #111).
- 2) Best temperature regulation is achieved by preheating the perfusion solution with an in-line heater (e.g., Warner SH-27B or SF-28) in addition to warming the chamber.