

Model PDMI-2

Micro-Incubator

User's Manual

PDMI-2 Micro-Incubator 65-0043

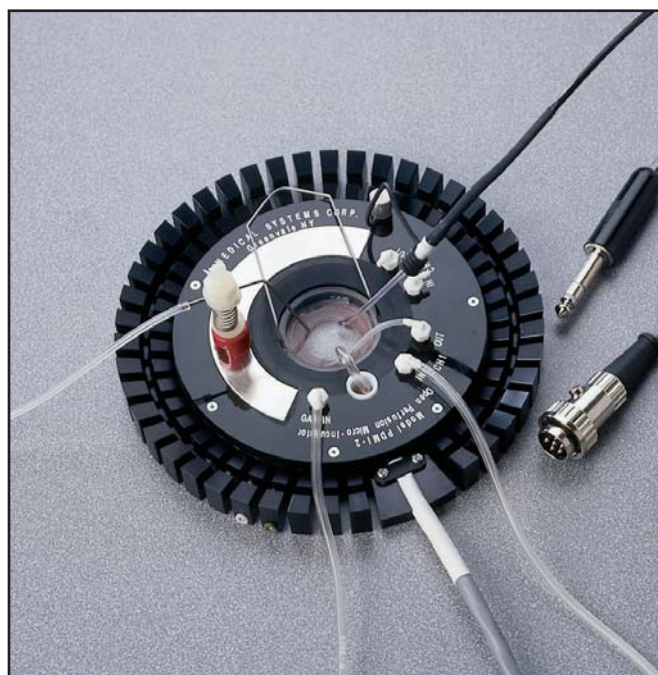

HARVARD
A P P A R A T U S

Table of Contents

1

Harvard Apparatus PDMI-2 Micro-Incubator User's Manual

SUBJECT	PAGE
Warranty Information	2
Specifications	3
General Information	4
Description	5-6
Controlling the Micro-Incubator	7
Setup and Operation	8-9
Perfusion.....	10-11
Maintenance	12
Troubleshooting	13
Footnotes.....	14
Appendices.....	15-19
Appendix A: Included Accessories.....	15
Appendix B: Optional Accessories	15
Appendix C: Peltier Device Use	16
Appendix D: Temperature/Current Data.....	17
Appendix E: Thermistor Calibration Table	18
Appendix F: Chamber Color Codes.....	19

Warranty and Repair Information

Serial Numbers

All inquiries concerning our product should refer to the serial number of the unit. Serial numbers are located on the rear of the chassis.

Calibrations

All electrical apparatus is calibrated at rated voltage and frequency.

Warranty

Harvard Apparatus warrants this instrument for a period of one year from date of purchase. At its option, Harvard Apparatus will repair or replace the unit if it is found to be defective as to workmanship or material.

This warranty does not extend to damage resulting from misuse, neglect or abuse, normal wear and tear, or accident. This warranty extends only to the original customer purchaser.

IN NO EVENT SHALL HARVARD APPARATUS BE LIABLE FOR INCIDENTAL OR CONSEQUENTIAL DAMAGES. Some states do not allow exclusion or limitation of incidental or consequential damages so the above limitation or exclusion may not apply to you. **THERE ARE NO IMPLIED WARRANTIES OF MERCHANTABILITY, OR FITNESS FOR A PARTICULAR USE, OR OF ANY OTHER NATURE.** Some states do not allow this limitation on an implied warranty, so the above limitation may not apply to you.

If a defect arises within the one-year warranty period, promptly contact ***Harvard Apparatus, Inc. 84 October Hill Road, Building 7, Holliston, Massachusetts 01746-1371*** using our toll free number 1-800-272-2775. Goods will not be accepted for return unless an RMA (returned materials authorization) number has been issued by our customer service department. The customer is responsible for shipping charges. Please allow a reasonable period of time for completion of repairs, replacement and return. If the unit is replaced, the replacement unit is covered only for the remainder of the original warranty period dating from the purchase of the original device.

This warranty gives you specific rights, and you may also have other rights which vary from state to state.

Repair Facilities and Parts

Harvard Apparatus stocks replacement and repair parts. When ordering, please describe parts as completely as possible, preferably using our part numbers. If practical, enclose a sample or drawing. We offer a complete reconditioning service.

CAUTION

This apparatus is not registered with the FDA and is not for clinical use on human patients.



CAUTION: Not for clinical use on human patients.

Specifications

3

Harvard Apparatus PDMI-2 Micro-Incubator User's Manual

Specifications

Electrical	Electrical Maximum: 6 amperes continuous (approx. 3 V DC)
Temp. Range	From 10° to 14°C below ambient to 50°C with TC 202A, (on conducting stage of microscope but without supplementary water cooling of heat fins)
Rate of Temp. Change	For 10° to 14°C change from 22° to 32°C perfusing at 1 ml/min into 3 ml, about 3 mins. with bipolar controller with Peltier plate control point. Slower rates (longer times) would be obtained with DC supply.
Perfusion Rate	Up to 3 ml/min. See Optional Reassembly in Maintenance Section on page 12 for higher rates
Thermal Expansion	Ranges between $\pm 4 \mu\text{m}$ between 15° to 30°C and $\pm 20 \mu\text{m}$ between 30° to 40°C
Plastic Perfusant Tubes	Teflon™ tubing (see #7 & 8 in Figure 1 on page 6)
Chamber Options	Corning 35 mm Petri dishes, LU-CSD, MSC-TD or MSC-PTD
Recommended Gas Flow	0.5 to 2.0 L/min
Temperature Stability	$\pm 0.2^\circ\text{C}$ with TC-202A, at 37°C with 1 ml/min perfusion
Temperature Gradient Across Chamber	2°C with 1.5 ml media volume, 1 ml/min perfusion
Built in Temperature Sensor	Thermistor: 100 k at 25°C - YSI 44011
Peltier Device Current Rating	Max. 6 A
Media Perfusion Rates	Up to 3.0 ml/min.
Overall Dimensions, H x D	17 x 152 mm (0.67 x 6.0 in)
Weight	0.5 kg (17.9 oz)
Microscope Stage Mounting	Call Harvard Apparatus, Inc. for options

General Information

The PDMI-2 Open Perfusion Micro-Incubator is a unique and versatile multipurpose cell/tissue culture unit which, in combination with its matching temperature controller (TC-202A), provides excellent control of both temperature and extracellular medium during:

1. Intracellular, whole cell or single channel patch recording from dissociated or cultured cells
2. Study of brain slice preparations
3. Long-term optical examination of living tissue

Cell culture is increasingly being used for electrophysiological and optical studies. Although this preparation offers the convenience of a controlled growth environment in the incubator, less consideration has been given to the microscope's environment where experimental examination takes place. One reason for this is the design problem associated with providing environmental conditioning, without limiting optical or electrode access or reducing the quality of any electrical recordings.

The PDMI-2 permits control of both temperature and composition of the extracellular medium. Three heat exchange interfaces to the culture's chamber allow perfusion to be stopped or started at will with minimal disturbance in temperature. Application of drugs or a change in the ionic composition is achieved without disturbing the set temperature or any electrodes. The PDMI-2 accepts Corning™ 35 mm plastic Petri dishes or an adapter holding glass cover-slips, (Leiden Cover Slip Dish³ (LU-CSD), HAI-TD or HAI-PTD LU-CSD-S (multi-well dish) cover slip dishes) available separately from Harvard Apparatus, Inc.

The PDMI-2 uses Peltier devices to drive the heat exchange. Appendix C, on page 16, describes their operation and identifies their advantages in this application. The design of the PDMI-2 avoids the normal need for Peltier cooling water except at the lowest control temperatures.

Design Considerations:

1. Compatibility with most popular microscopes.
2. Provides excellent mechanical and optical access for ease of cell/tissue manipulation and observation.
3. Allows temperature regulation both above and below room temperature with perfusant media supplied to the PDMI-2 at room temperature.
4. Allows temperature to be regulated either in the chamber bath (with the external thermistor probe supplied with the recommended TC-202A temperature controller) or with the built-in thermistor (useful when shallow media levels are being used).
5. Maintenance of constant (low) fluid level during perfusion.
6. Use of 35 mm Corning™ plastic Petri dishes or glass cover-slips.
7. Small chamber and upstream volume to allow rapid media change.
8. Electrical isolation of heat exchange plates from chamber electrical ground. This allows reduction of electrical noise by using a single external connection between signal ground and power ground.

Description

5

The Open Perfusion Micro-Incubator (PDMI-2) is an annular shaped assembly (see Figure 1, page 6) surrounding the central chamber (either a disposable plastic 35 mm Corning™ Petri dish or the reusable Cover Slip Dish 35 mm Ø).

The PDMI-2 contains two metal round plate assemblies to effect the heat transfer to the chosen chamber:

1. The lower plate assembly (black aluminum plate) has a flat bottom surface to which the appropriate alignment ring is attached to form a mating surface with the microscope. This lower assembly serves also as a radiator of Peltier pumped heat via radial cooling fins (see Figure 1, page 6) on its outside diameter.
2. The top plate (see Figure 2, page 6) also black aluminum supports the inserted chamber and serves as the temperature driven plate.

Heat transfer to or from the chosen chamber is driven by two Peltier thermoelectric devices, which when powered by a suitable feedback controller, can regulate a centrally located chamber temperature to $\pm 0.2^{\circ}\text{C}$.

Heat transfer to the controlled medium during perfusion occurs largely from the temperature driven plate to closely coupled Teflon™ perfusion tubing. The Teflon™ tubes are coiled inside a circling slot (groove) machined in the top heat exchange plate (see Figure 2, page 6). The extracellular medium first passes through these tubes and is warmed (or cooled) to the set temperature before reaching the chamber. There are two other heat transfer mechanisms. The first of these is by direct conduction from the support surface and collar to the chamber, the other is through convection from air or gas flowing over the same temperature controlled plate.

Several different modes of operation are permissible:

1. Static chamber medium at a constant set temperature.
2. Continuous perfusion at a constant set temperature.
3. Switching perfusion of extracellular medium at a set temperature.
4. Discontinuous perfusion.
5. Rapid temperature changes (with perfusion).

Why perfuse the chamber?

The ability to change the extracellular environment by perfusion is important for two reasons: first because static experiments carried out above ambient temperature may incur rapid evaporation from small experimental chambers. (An oil layer at the liquid/air interface will avoid this and better insulate the system thermally⁵); and second, perfusion is essential for quantitative ionic and pharmacological studies, or for studies of distributed synaptic inputs or network activity, in which drugs need to be applied to a large area. Perfusion is especially useful for the application and subsequent washout of an antagonist at a precise concentration.

Description

6

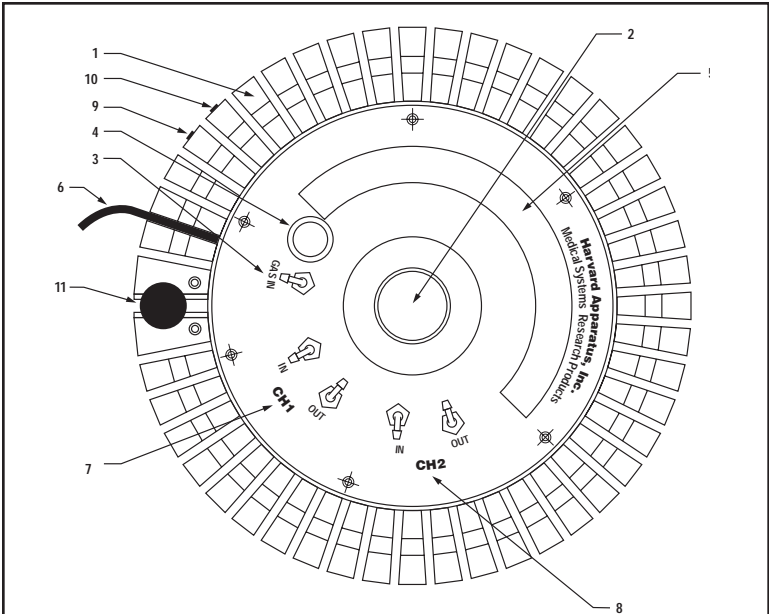

Figure 1. Top View of PDMI-2

- | | |
|----------------------------|---------------------------------------|
| 1. Fins | 6. I/O Cable |
| 2. Chamber Optical Window | 7. Ch. 1 Perfusion Lines |
| 3. Salt Bridge Well | 8. Ch. 2 Perfusion Lines |
| 4. Gas Inlet | 9. Plate Ground Socket (green) |
| 5. Surface to Hold Magnets | 10. Salt Bridge Ground Socket (white) |

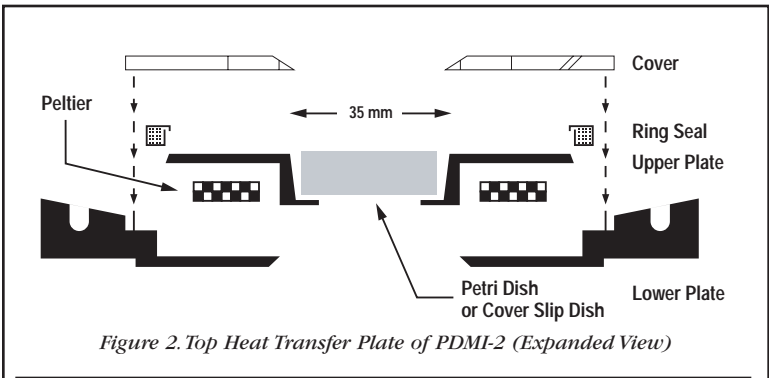

Figure 2. Top Heat Transfer Plate of PDMI-2 (Expanded View)



Figure 3. Top Heat Transfer Plate of PDMI-2 (Assembled View)

Controlling the Micro-Incubator

The PDMI-2 has built-in Peltier heating/cooling elements. Current passed in one direction will heat the enclosed dish, reversed current will cool it. **WARNING:** The maximum sustained current is about 6 amperes. This corresponds to a maximum voltage applied across the two Peltier leads of about 3 volts. Two methods of control are possible, manual or feedback. A manual system uses a DC power supply; the direction and magnitude of the current through the micro-incubator is adjusted by hand. For better performance, the feedback method is preferred. In this method, the current supplied is automatically adjusted in magnitude and, with the TC-202A, direction depending on the difference between the actual and the desired temperature. The advantage of feedback is that the calibration curve (chamber temperature versus controller setting) is unaffected by ambient temperature changes. In the cooling direction, however, the lowest temperature reachable will still depend on the degree of contact with the microscope stage and the ambient temperature.

Manual Control

The power supply should deliver constant current (rather than voltage) and be adjustable up to the maximum needed for the desired temperature range. Use the approximate calibration of chamber temperature versus current for low perfusion rates (Appendix D, page 17) to determine this. At higher perfusion rates more current will be needed for a given temperature, for static solutions, less current. This data will also be affected by ambient temperature, the depth of media in the chamber, and the degree of contact of the PDMI-2 with a large metal surface such as a microscope stage. The data of (Appendix D, page 17) can be used approximately at other ambient temperatures since it is expressed as temperature difference from ambient versus current. For accurate calibration, produce your own graph of temperature directly measured in the chamber versus current. See Setup and Operation for correct polarity of the power supply connections.

Feedback Control

The control for temperature can be from the thermistor mounted on the top heat exchange plate (built-in thermistor) compatible only with the TC-202A temperature controller or from a thermistor placed in the chamber itself. These locations are complementary in their performance. Choose accordingly. The plate temperature will be 1° to 2°C further from ambient than the chamber temperature. Its advantage is that the controller doesn't go out of control if the fluid runs out or drops below the level of the chamber thermistor. The TC-202A has been designed as a bipolar and monopolar unit. To achieve the feedback control and obtain maximum benefits from your PDMI-2 Micro-Incubator, we strongly recommend that you use the TC-202A on its bipolar mode. (See TC-202A setup for more information). This temperature controller should be used for best results.

TC-202A Features

1. Allows the PDMI-2 to either cool or heat the bath preparation as well as control temperatures near ambient equally well.
2. Automatically switches the current direction when the sensed temperature is higher or lower than the set point temperature.
3. Allows fast changes in temperature.
4. Allows $\pm 0.2^\circ\text{C}$ regulation.
5. Controls the PDMI-2 either with the micro-incubator's internal thermistor or with the TC-202A (supplied) thermistor.
6. Uses low ripple DC current for temperature control to allow low noise electrical recording without interference.
7. Automatically shuts power off to the TC-202A (no current will pass) when excessive temperatures are reached so that possible system damage during "feed forward failure" is avoided (see Troubleshooting, page 13).

Setup and Operation

Note on Orientation: Any references to right and left assume the unit is viewed as in Figure 1 from above with the electrical cable to the left (see Figure 1, page 6).

1. Mounting on the Microscope

The PDMI-2 bottom plate has a flat surface for unrestrained mounting on various inverted microscope stages. Accessories are available to lock the PDMI-2 to the stages of the microscopes from several manufacturers.

The locking devices come in two forms:

- As alignment rings that assemble to the bottom of the PDMI-2 and, in turn, fit on opening in the microscope stage.
- As fixing platforms that fit a locking mechanism of Zeiss or Leica attachable mechanical stages.

Using a stage attachment accessory has the advantage of improved mechanical stability and gives the user the ability to use the microscope stage built in X-Y manipulators to position the chamber in the field of view.

The following microscope stage locking accessories are available:

- PDMI-ARN:** Alignment Ring for Nikon Diaphot (old or 300/200) TMD stage
107.75 mm \varnothing x 1.78 mm H (4.242" \varnothing x 0.071" H)
- PDMI-ARZ:** Alignment Ring for Zeiss Axiovert gliding or rotary stages
102.75 mm \varnothing x 1.78 mm H (4.046" \varnothing x 0.071" H)
- PDMI-ARO:** Alignment Ring for Olympus IX50/70 or IMT-2 fixed stage
109.73 mm \varnothing x 1.78 mm H (4.320" \varnothing x 0.071" H)
- PDMI-FPZ:** Fixing Platform for Zeiss Axiovert with attachable mechanical stage.
- PDMI-FPL:** Fixing Platform for Leica DAS Microscope DMIL and DMIRB/E with attachable mechanical stage.
- PDMI-ARL:** Alignment Ring for Leica Microscope
88 mm \varnothing x 1.8 mm H (3.52" \varnothing x 0.072" H)

These rings or platforms are easily attached to the bottom plate with 3 small screws supplied with each ring or platform.

2. Electrical Connections

The PDMI-2 main cable has a multi pin connector at its end. This connector matches the TC-202A front panel I/O jack. This cable provides the electrical connections for:

- Power to the PDMI-2 Peltier heat pumps.
- The PDMI-2 built-in temperature feedback thermistor. A table of its electrical resistance versus temperature is shown in Appendix E, page 20. Note that this temperature is not exactly the same as that in the media in the dish.
- System ground. The micro-incubator's ground scheme is designed to provide the best possible noise shielding for demanding electrical recordings. The PDMI-2 heat exchange plates are anodized and thus not electrically in contact with the microscope stage. These plates are also electrically separated from the Peltier power leads. One of those Peltier power wires is grounded within the TC-202A. The micro-incubator body (heat exchange plates) is grounded to the temperature controller chassis by the metal shell connector on the PDMI-2 cable.

Setup and Operation

Two independent (separate from the main cable) ground pathways are also available when single channel or similar demanding electrical recordings are to be performed:

- a. **Salt Bridge Ground:** The Ag/AgCl disc in a salt bridge well (see #3, Figure 1, page 6) is connected to a small 1 mm diameter white color socket (see #10, Figure 1, page 6). This allows grounding of the recording chamber via an integral agar/salt bridge.
- b. **Shield Ground:** A small 1 mm diameter green color socket (see #9, Figure 1, page 6) connected to the cable shield and aluminum components of the PDMI-2. Connecting this to a local ground can sometimes reduce 50/60 Hz interference.

3. Temperature Probes

If the PDMI-2 is to be driven from the chamber, an external thermistor (appropriate for the temperature controller in use) should be placed in the chamber itself. A small thermistor holder to position the thermistor probe tip into the chosen chamber (optional reusable cover slip dish or plastic petri dishes) is supplied with the micro-incubator.

The thermistor holder is attached to the top of the PDMI-2 upper plate by a thumbscrew. Thermistor probes available from Harvard Apparatus, Inc. are:

- a. The BSC-T3 thermistor probe for use with the TC-202A.
- b. The BSC-T2 thermistor probe for use with the old TC-102.

4. Chambers

Either disposable 35 mm Corning™ Petri dishes or the reusable cover slip dish (HAI-TD, HAI-PTD, LU-CSDS) can be used in the PDMI-2. Place the chosen chamber in the PDMI-2 central well.

Note: For optimal fit with good heat exchange use the Corning™ 35 mm dish model 25000.

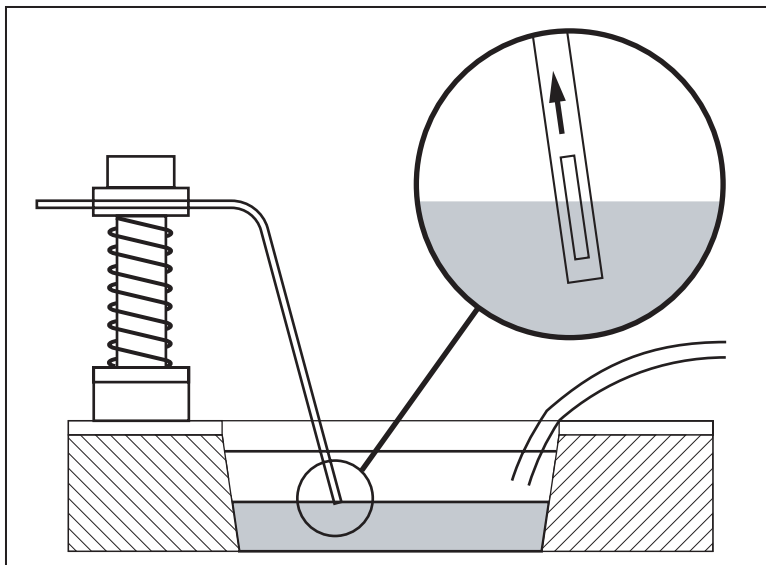

Figure 4. LU-ASP Aspirator

Outlet from the chamber is by direct suction. The included aspirator (LU-ASP) was originally developed by Dr. Can Ince, University of Leiden, for patch clamp applications. The design of this aspirator cleverly avoids fluid level variations (a source of electrical noise) in electrical recording experiments. The aspirator has a magnetic base to grip a matching magnetic surface (see #5, Figure 1, page 6) on the top of the top plastic plate of the PDMI-2. Connect up a source of suction with a liquid trap to this aspirator. The level of fluid in the chamber is determined by the height of this aspirator and can be changed with its thumbscrew. The oscillations inherent in any peristaltic perfusion are easily damped with bubble-traps. Such traps also allow the independent chamber grounding required for low noise electrical recording.

Fluid Perfusion

For reliability at low flow rates a peristaltic pump is preferable to gravity feed. This also makes it easier to maintain fluid level on changing solutions. A four channel pump is ideal since this allows for perfusion of several different solutions. Two small 90° elbow (white) inputs (CH1 "IN" or CH2 "IN") are provided in the micro-incubator. In addition, two small 90° elbow (white) outputs (CH1 "OUT" or CH2 "OUT") are provided for tubes that can be user directed to the desired location in the chamber. Changing the perfusate can be achieved by switching between the two corresponding pump channels attached via a valve to one of the PDMI-2's perfusion inlets.

Complete Layout of Liquid Perfusion

For one possible complete layout of liquid perfusion, see Figure 5 on next page.

Temperature Gradients

The temperature at any particular point in the recording chamber is dependent on the mode of operation and the rate of perfusion. The horizontal temperature gradient

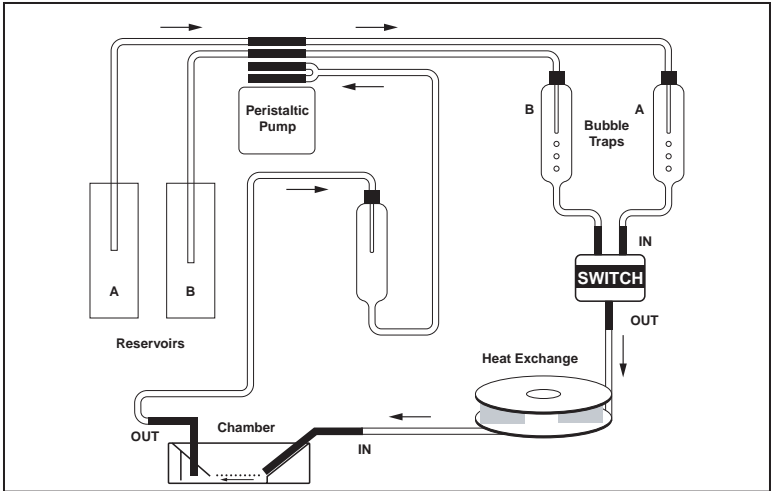

Figure 5. Perfusion System

depends on media perfusion rate, gas flow rate, depth of media and the presence or absence of a cover lid. For absolute determination during a particular experiment it is essential to measure the temperature directly.

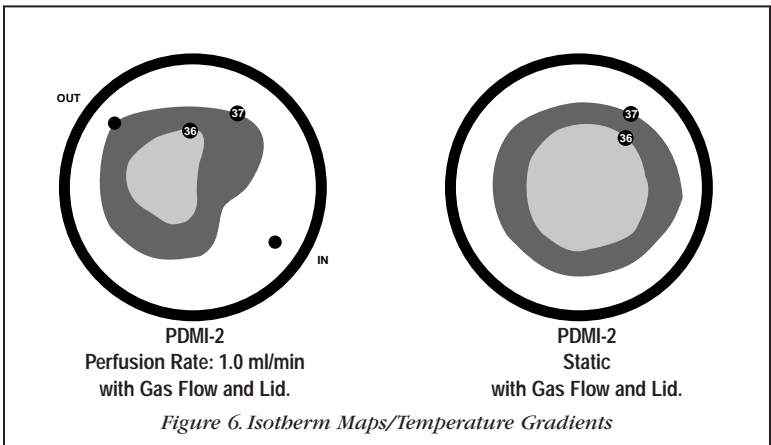

Figure 6. Isotherm Maps/Temperature Gradients

Gas Perfusion

This is intended primarily to reduce the heat loss to (or gain from) the local atmosphere, thereby reducing temperature gradients across the dish. It is possible to control the gas mixture above the perfusion chamber. The gas passes over the same heat exchange as the fluids. Any desirable gas mixture may be introduced into the micro-incubator (e.g., 5% CO₂-air mixture can be used with a bicarbonate buffer medium). An inlet for CO₂ has been incorporated into the PDMI-2.

The PDMI-2 requires only a minimum of maintenance. Periodically replace the tubing (26 AWG Teflon™) to avoid clogging by dust particles or growth of microorganisms. With daily use replace this tubing every two months. The period between changes can be increased by flushing with distilled water after use. This may be followed, perhaps, by modest heating to dry out the tubing. An occasional perfusion of 70% alcohol helps.

The Ag/AgCl disc in the chamber ground can be pretreated for minimum DC offset and noise. Pre-fill the plastic well (see #3 in Figure 1, page 6) in the PDMI-2 with the desired salt solution and let it soak for 2 to 4 hours. A faster method is to immerse a silver wire in the filled well and apply an AC voltage between it and the white lead of the PDMI-2. A two minute application (60 Hz) is sufficient with no more than a few milliamps (preferably at 400 Hz or higher). With frequent use, the Ag/AgCl disc may occasionally require replacement. Return your PDMI-2 to Harvard Apparatus for Ag/AgCl disc replacement (see General Information, page 2).

Disassembly for replacement of tubing (see Figure 2, page 6):

1. Remove the six screws (outside rim) of the cover, observing carefully how the perfusion tubes are fed through their entry and exit points from the outer circular “bobbin” of the exposed heat exchange plate.
2. Remove the tubing. If better heat transfer is needed, use heat sink compound (for white paste - zinc oxide contact an electronics repair shop to obtain some) or silicone oil in the bobbin's groove. Wind new tubing (see Specifications, page 3) through the same slots from the bobbin itself. Cut the tubes to the desired lengths and thread them through those slots. Reseat the plastic ring that circles the outside of the exposed heat exchange plate, (first rubbing a little silicone oil on its top and bottom surfaces) and position the plastic plate.

Note: For easy insertion in silicon gasket (inside of 90° elbow fitting) cut end of Teflon™ tubing at 45°.

3. Reattach the plastic plate with the six screws. Be careful in tightening the screws to avoid stripping.

Optional Reassembly

For faster perfusion rates, lengthen the tubing on the bobbin by selecting another exit point or else reduce its wall thickness (see Specifications, page 3). Either allows the faster moving fluid to still get enough heat transfer before reaching the chamber.

Suggestion: Use only one tube and wind it one extra turn (one and three quarters total) for the same exit point. This should allow perfusions of as much as 6 ml/min.



WARNING: Do not further disassemble the PDMI-2. Once the top heat plate is removed, reassembly for good seat is tricky.

Troubleshooting

Problem	Cause	Solution
1. Slow perfusion rate or excessive fluid build-up in bubble trap.	Due to excessive perfusion rate. Blocked heat exchange tubing.	First, flush tubing with 70% alcohol and then perfuse distilled water for one hour. If still a problem, then change Teflon™ tubing.
2. Very hot fins/plate, too hot to touch "feed back temperature control disrupted"	Too much heat is generated at Peltier junction nominally at ambient temperature.	Resume operation after device has cooled off preferably after taking actions suggested under one of the following .
	You have not placed device in contact with adequate metallic thermal mass or are trying to cool to too low a temperature.	Check if microscope stage is thermally conducting. Apply heat sink compound or silicone oil to supporting metallic surface of microscope or install water perfusion (See Appendix B.)
	Attempted operation outside recommended range if control point was chamber temperature and its thermistor was uncovered due to failure in perfusion system.	Either monitor perfusion system more closely or else switch (with TC-202A) to Peltier plate control.
3. Temperature Controller not supplying current.	"feed forward failure" occurs with the TC-202A, it automatically stops delivering current.	Wait for Peltier plate temperature to cool off. Use one of the solutions in #2 above to avoid repeated lapses in current.
4.Excessive 60 Hz pick-up, baseline drift or noise if electrically recording.	Fluid creep can short this to plate.	Check for ground path between chamber ground connection and metal plates. Dry agar bridge and petri dish, wipe surfaces with silicone wax or oil to ensure they are hydrophobic.
	Drift in baseline when electrically recording is most likely due to one of Ag/AgCl junctions in complete recording circuit. Bath thermistor is not completely disconnected.	If problem localized to PDMI-2's pellet, PDMI-2 should be returned to Harvard Apparatus, Inc. for replacement.* For single channel patch clamp recording, bath thermistor should be completely disconnected for lowest noise. (Prior calibration will allow determining of chamber temperature from plate temperature). Ground loops (causing noise) are avoided by using only one grounding point preferably near chamber. Connect patch clamp ground, bath ground (white pin) and (most likely) heat exchange plate ground (green pin) here. Source of ground loops can be subtle.
5.Static discharge during perfusion.		Check earthing system and fluid level in bubble traps. Simplest way to solve problem is to use stainless steel needles in bubble traps and earth them.

* Note: See Maintenance, page 12 for ways to pretreat pellet to reduce offset.

1. Forsythe, I.D. et al "A chamber for electrophysiological recording from cultured neurons allowing perfusion and temperature control," Journal of Neuroscience, Meth, 2d, 19-27, 1988. This article describes a prototype of the PDMI-2 without provision for gas flow.
2. Forsythe, I.D., et al "An open perfusion micro-incubator for electrophysiological recording in vitro," Journal of Physiology, (London), 410, SP 1989. This article describes the addition of gas flow to the device and the elimination of the need for water cooling.
3. Ince, C. et al "A teflon culture dish for high magnification microscopy and measurements in single cells," Pflugers Arch, JU, 240-244, 1985.
4. Purves, R. D., ed. "Earthing and Interference," Microelectrode Methods. @ Intracellular Recording and Iontophoresis, pages 55-65, Academic Press (London), 1981
5. DeHaan, R. L. et al, Journal of General Physiology, 65, 207, 1975.
6. Ince, C. et al, "Micro CO₂. Incubator for use on a microscope," Journal of Immunology, Meth, 60, 269-275, 1983. This paper describes the use of gas flow to reduce vertical and horizontal temperature gradients and to control pH in an optically accessible chamber.
7. Forsythe, I, "An environmental chamber regulating temperature and super fusion of tissue cultured neurons during electrophysiological or optical studies," Electrophysiology and Microinjection, Methods in Neuroscience, volume 4, 301-320, Academic Press, New York Ed.: Conn, P.M., 1991. This article provides a complete description of the final version of the PDMI-2 and its operation.

Appendix A: Included Accessories

1. Aspirator (LU-ASP) (see Perfusion, page 10).
2. Plastic disposable Petri dishes, sleeve of 20: Corning™ part 25000.
3. Lid to close open top of chamber for longer term studies or reduced horizontal temperature gradient. (The three screws on the lid are for height adjustment only.)
4. Teflon™ perfusant tubing. If Teflon™ is used in the PDMI-2, add short lengths of Silastic tubing to the end(s) going into the chamber to allow chamber insertion and removal. Teflon™ may be more appropriate for use of some perfusants.
5. Wires with 1 mm plugs (for salt bridge and plates ground connections) on one end and bare wire on the other.
6. Thermistor holder attached to PDMI-2 (1 spare).

Appendix B: Optional Accessories

1. A waterproof temperature probe to measure temperature within the chamber.
TC-202A: This Temperature Controller comes with a suitable chamber thermistor (BSC-T3).
2. Copper tube for water perfusion is necessary for very low temperatures to prevent feed - forward condition. Place tubing in circular groove (0.45 cm wide) on top of air fins. (Available from Harvard Apparatus' Bioscience Catalog.)

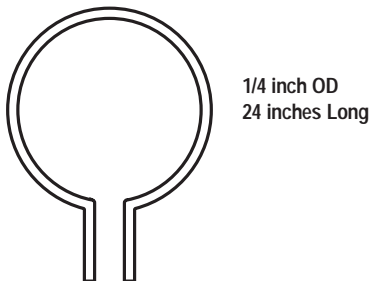

Figure 7. Copper Tubing

Appendix C: Peltier Device Use

A thermoelectric module is a solid state device consisting of a series of semiconductors. Most commercial devices are made from p and n doped bismuth or lead telluride. The passage of electric current normally generates only heat. The contradictory concept of the Peltier effect is due to Jean Peltier who in the nineteenth century discovered that the passage of current through two dissimilar conductors results in the junction either heating up or cooling down. Each device consists of many couples mounted in series and connected by copper strips; sometimes overlying this is a thin piece of ceramic, an electrical insulator, but thermal conductor. In principle they work as heat pumps; that is when current is passed through the junction, the device pumps heat in one direction, reversing the current reverses the direction of the heat flow. Thus depending on the capacities of the heat source and sink, a temperature gradient is built up across the device. The thermoelectric device is thus sandwiched between the object of interest and a suitable thermal mass or heat sink.

Use of Peltier Devices

Peltier devices are essential for rapid temperature changes or when the desired temperature is close to ambient temperature (because they can actively correct the actual temperature whether too high or too low instead of relying on the slow passive return of a resistive heater system). These advantages are only available when a bipolar temperature controller is used, see Section III. Peltier devices also offer the flexibility to cool as well as heat in the same chamber. Such a system further allows examination of the temperature dependence (Q_{10}) of biological properties by changing the command temperature rapidly during an experiment. Finally, lowering the temperature eases the study of ion channels with rapid kinetics.

Appendix D: Temperature/Current Data

Conditions

Ambient temperature 23°C chamber liquid perfusion 0.5 ml/min gas flow 50 ml/min with cover plastic Petri dish with 1.75 ml of media Nikon Diaphot microscope no cooling water for Peltiers.

Current (amperes)	Chamber Temp. (°C)	Delta Temp. (°C) *
-4.1	9.4	-13.6
-3.6	10.1	-12.9
-3.1	10.6	-12.4
-2.8	5	11.3-11.7
-2.56	12.1	-10.9
-2.3	12.6	-10.4
-2.0	13.5	-9.5
-1.8	14.5	-8.5
-1.55	15.1	-7.9
-1.35	16.1	-6.9
-1.15	17.1	-5.9
-0.95	18.2	-4.8
-0.75	19.4	-3.6
-0.55	20.7	-2.3
-0.35	21.9	-1.1
0.15	24.1	1.1
0.35	26.0	3.0
0.65	27.8	4.8
0.95	30.2	6.8
1.2	32.4	9.4
1.5	34.8	11.8
1.8	36.4	13.4
2.1	39.4	16.4
2.5	45.4	22.4
2.9	49.0	26.0

* This temperature difference is between the chamber and ambient (positive when chamber above ambient). Use this column to estimate data of chamber temperature versus current for other ambient temperatures.

Appendix E: Thermistor Calibration Table

Resistance Data: PDMI-2 Internal Thermistor			
Temperature (°C)	Resistance (KΩ)	Temperature (°C)	Resistance (KΩ)
4	271.6	25	100.0
5	258.3	26	95.3
6	245.7	27	91.3
7	233.8	28	87.4
8	222.5	29	83.6
9	211.9	30	80.0
10	201.7	31	76.6
11	192.2	32	73.3
12	183.1	33	70.2
13	174.5	34	67.3
14	166.3	35	64.4
15	158.6	36	61.75
16	151.3	37	59.2
17	144.3	38	56.75
18	137.7	39	54.5
19	131.4	40	52.2
20	125.5	41	50.1
21	119.8	42	48.0
22	114.5	43	46.1
23	109.4	44	44.3
24	104.5	45	42.5

Appendix F: Chamber Cable Color Codes

From the first release to the market of the PDMI-2 Micro-Incubators to the current design, there have been various design changes. A wiring color code of the different units released is provided below to aid the wiring of the PDMI-2 cable to the chosen temperature controller's power/control output. In the current version, the PDMI-2 is provided with a connector which matches the TC-202A output connector. For other options the table below may be used. In any case, we suggest that you contact Harvard Apparatus, Inc. for instructions or more details.

PDMI-2 Wiring Codes

	<u>Wire Size</u>	<u>Final</u>
Peltier +	AWG 20	Red
Peltier --	AWG 20	Black
Signal Ground (salt bridge)	AWG 26	1 mm White (connector)
AC Ground (60 Hz noise)	AWG 26	1 mm Green (connector)
Thermistor	AWG 26	Green
Thermistor	AWG 26	White

